

VGURB-1807HUBK INSTALLATION INSTRUCTIONS

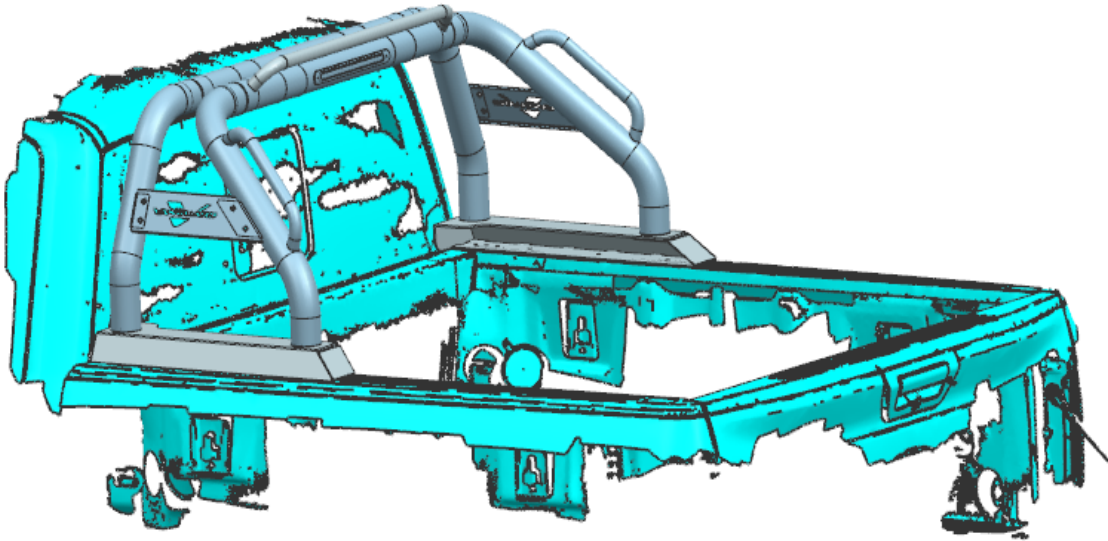

60 Minutes

⚠ IMPORTANT:

Please read each step of these instructions carefully prior to commencing installation!

Place these instructions in the vehicle's glovebox after installation is complete

⚠ IMPORTANT:

- Do not use this product in any other motor vehicle for which it is not designed.
- Do not use any other mounting location / method other than described in this instruction.
- It is advisable to seek assistance of another person when installing this product.
- Do not remove the label from the Sports Bar.
- Ensure all torque settings are followed.

Note: This is an Aluminium product. **Beware of belts, buckles zippers, etc. when lifting Sportsbar as these will easily damage the finish.** To avoid corrosion stains, clean up after completion of installation - remove all drill swarf & wipe all fingerprints from car & product.



INSTALLATION PRECAUTIONS

Follow all standard workshop and occupational health and Safety practices during the installation and re-work process.

Safety glasses and hearing protection must be used. Avoid contact with the hot steel when the vehicle tray is being drilled or cut. Clean up the swarf from the bumper fascia re-work immediately to avoid a slipping hazard.

■ INSTALLATION PRECAUTIONS

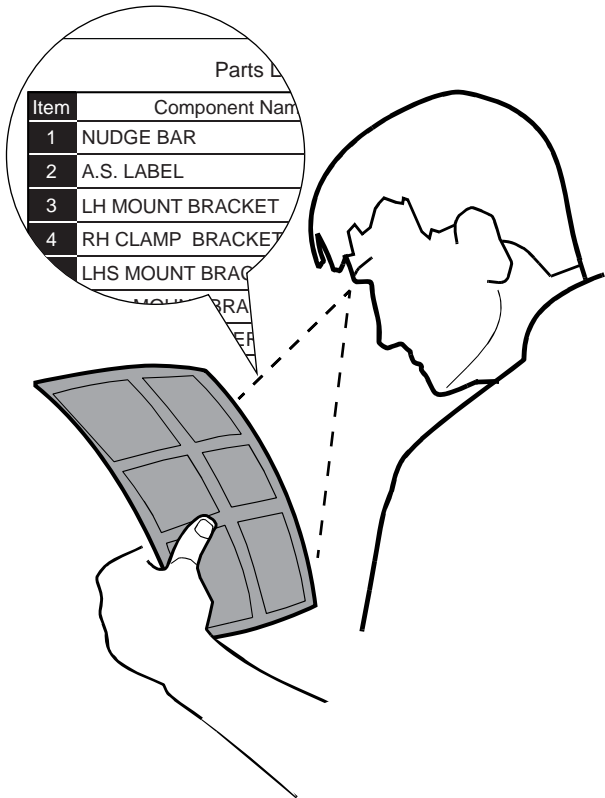

STOCKTAKE OF PARTS

Check supplied Sports Bar parts and fasteners against BOM, before commencing assembly or modifications to the vehicle.

■ STOCKTAKE OF PARTS (PARTS LIST IN ILLUSTRATION IS AN EXAMPLE ONLY)

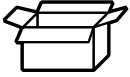

ITEM	DESCRIPTION	SPECIFICATION	QTY.
A	Main body 1 of roll bar	DIA 76.2, 1.2mm WALL SECTION	1
B	Main body 2 of roll bar	DIA 76.2, 1.2mm WALL SECTION	1
C	Main body 3 of roll bar	DIA 76.2, 1.2mm WALL SECTION	About 2 points
D	Main body 4 of roll bar	DIA 76.2, 1.2mm WALL SECTION	About 2 points
E	Main body 5 of roll bar		1
F	Main body 6 of roll bar		1
G	MOUNT bracket 1		About 2 points
H	bolt	M8*25-8.8	4
I	Flat washer	M8	6
J	Lock washer	M8	6
K	Nut	M8	2
L	bolt	M6*10	8
M	Flat washer	M6	8
N	bolt	M10*25	8
O	Round head hexagon screw	M10*40	4
P	Flat washer	M10	12
Q	Lock washer	M10	12
R	Nut	M10	8
S	Rubber Pad		4
T	bolt	M8*30-8.8	2
U	MOUNT bracket 2		About 2 points
V	Latin nut	M10	8
W	BOLT	M10X45(TEETH LONG 25)	1
X	Flat washer	M10	2
Y	NUT	M12	1
Z	Chrysanthemum flat Washer	M10	1

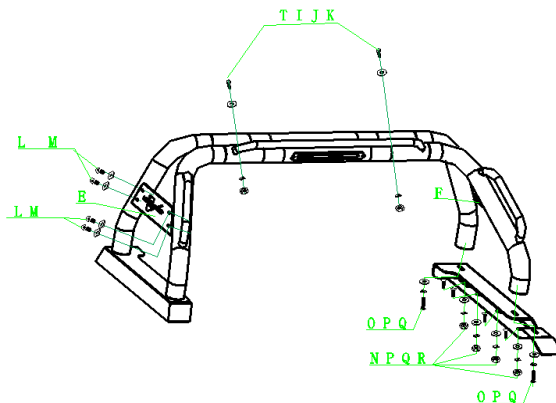
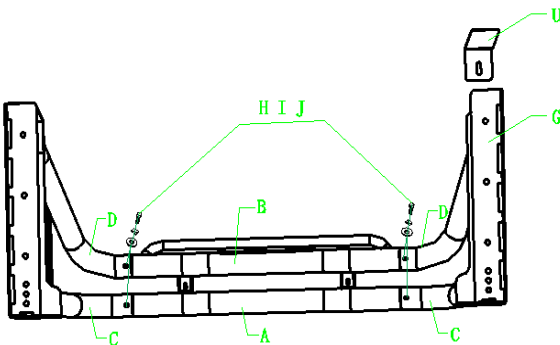
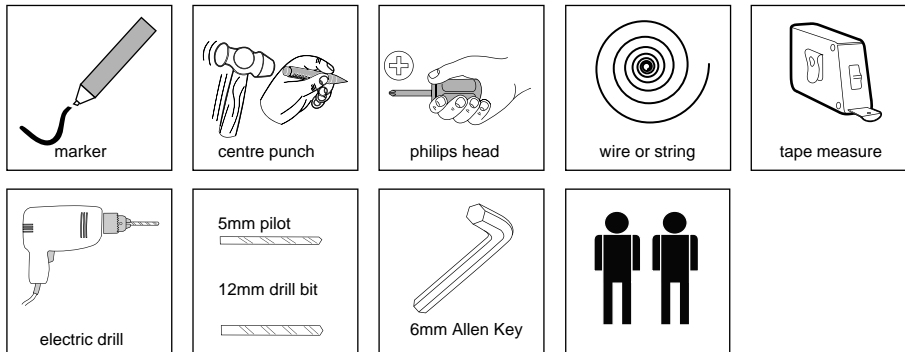
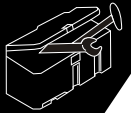

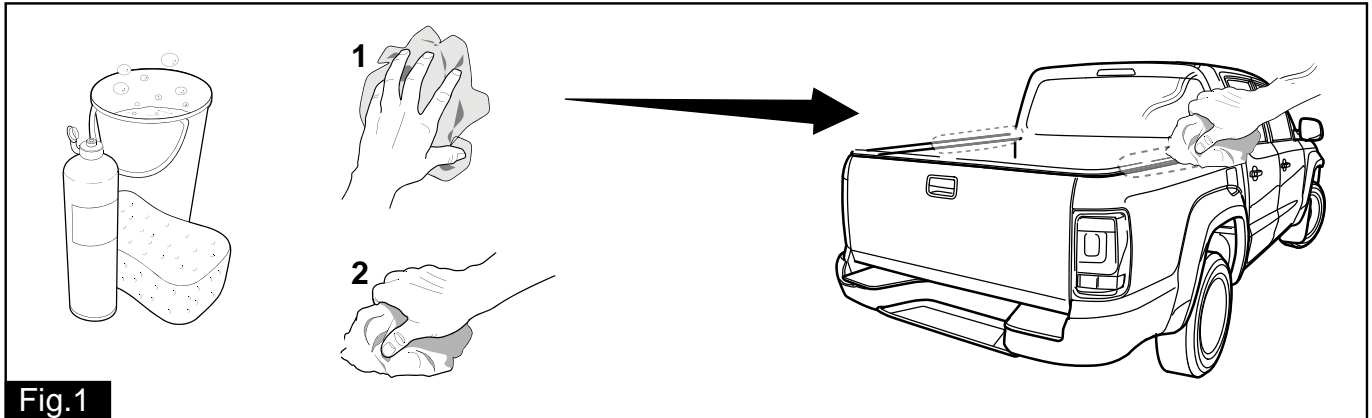

Fig.1

1. NOTE: Two people are required to complete installantion. Thoroughly clean and dry the installation areas. **See Dia#1**

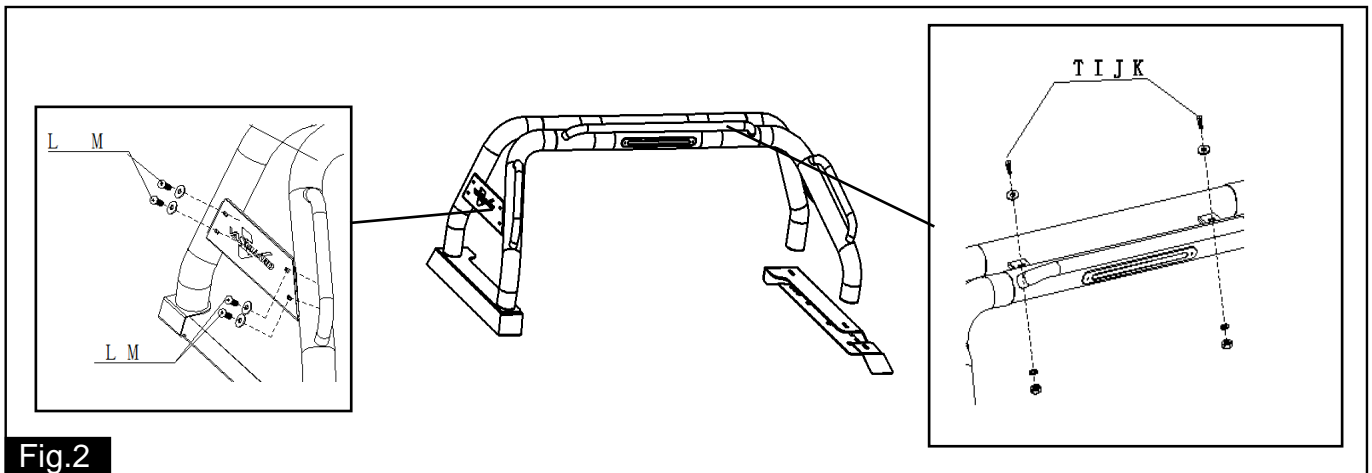

Fig.2

2. Slide rubber sleeves away from join and temporarily secure sports bar top tube to sports bar left and right hand legs using two (2) M8x30 black screws and M8 flat washers and M8 lock washers and M8 nut.

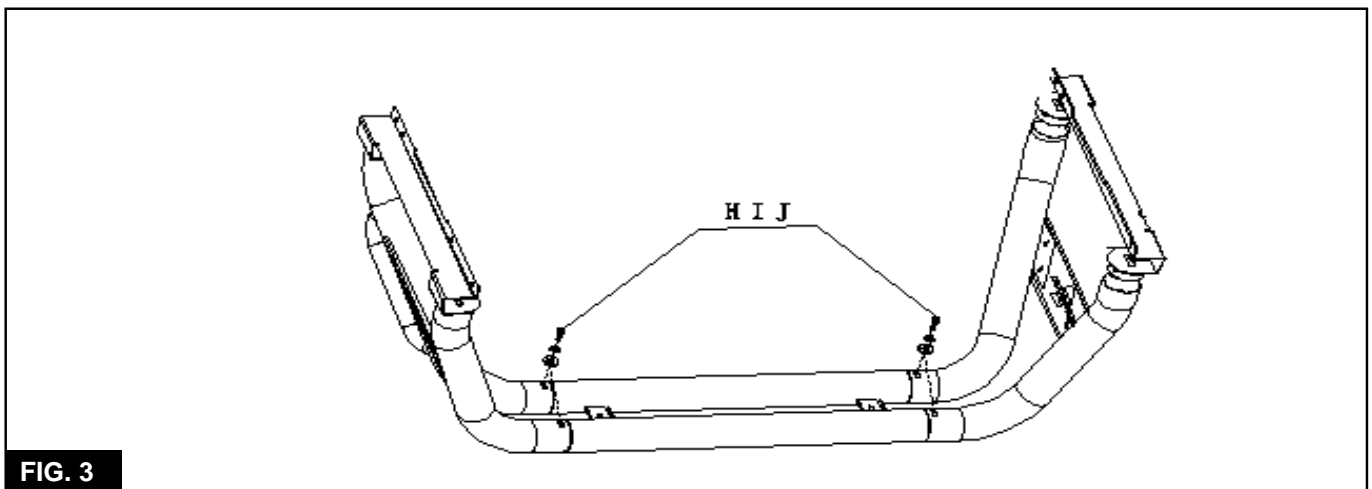

FIG. 3

3. Slide rubber sleeves away from join and temporarily secure sports bar top tube to sports bar left and right hand legs using four (4) M8x25 black screws and M8 flat washers and M8 lock washers.

See Dia#3

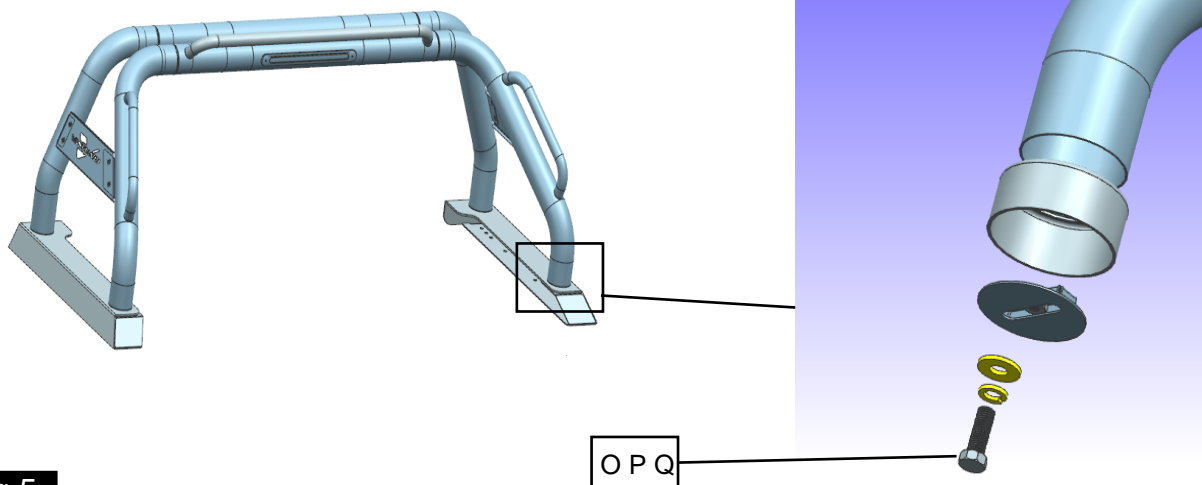
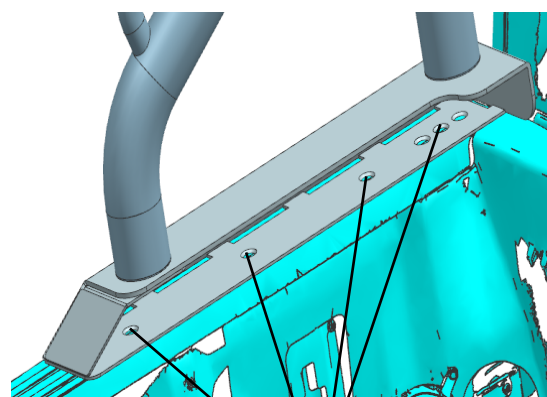
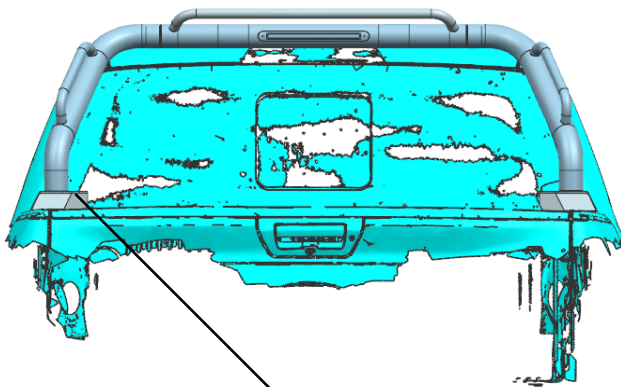

Fig.5

5. Attach the moulded leg bracket cups and foam gaskets to the sports bar legs as shown.

See Dia#5



MARK HOLES

Fig.6

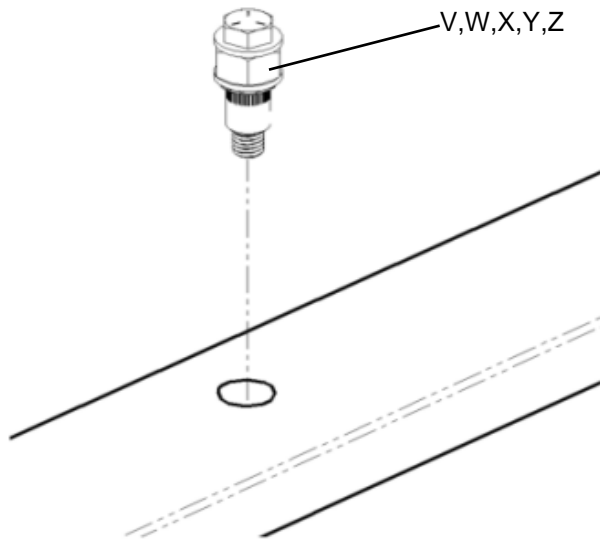

- Drill $\varnothing 13.5$ holes through top side of bed rails.
- Apply automotive primer to any exposed metal.
- Hand tighten Rivet nut, Item M10 lahm to Rivet Nut Install Tool, Item M10 hex bolts.
- Insert Rivet Nut into $\varnothing 13.5$ hole.
- Hold spacer with wrench.
- Tighten bolt with wrench or socket and ratchet, this will compress the rivet nut.
- Once tight, unscrew the bolt and rivet nut will be installed.

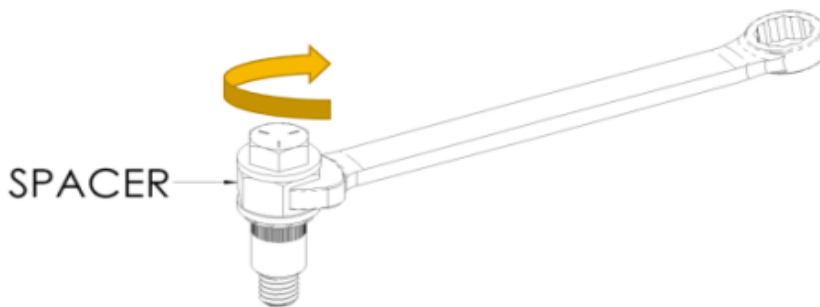

- If hole was drilled through top and bottom, attach the sport bar using (3) M10 flat washers, (3) M10 lock washers and (3) M10 flat head bolts, per side.

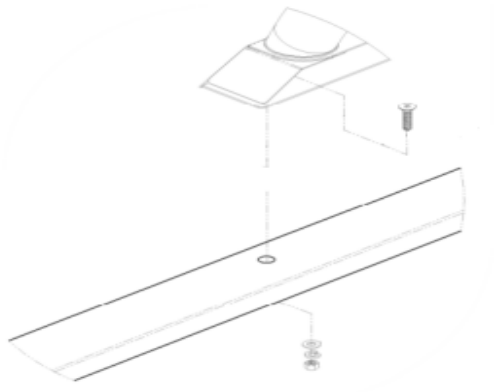

- If Rivet Nuts were installed, attach the sport bar using (3) M10 flat head bolts, per side.

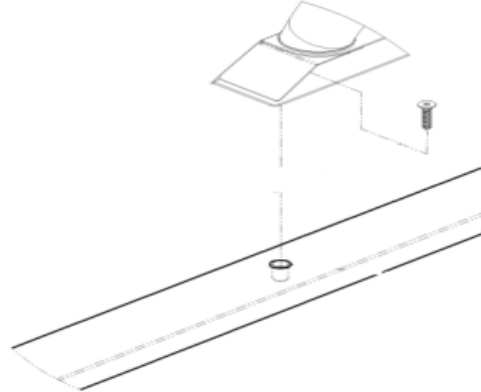

- Tighten all front and rear tube bolts to 8m Max. **DO NOT OVERTIGHTEN BOLTS**
 - Check and retighten all nuts and bolts periodically.