

INSTALLATION INSTRUCTIONS

2015 - Current Chevrolet Colorado

ⓂBGG-2048HUBK

PARTS LIST:

Qty	Part Description	Qty	Part Description
1	Grille Guard	2	10-1.5mm x 80mm Hex Bolts
1	Driver/left Frame Mounting Bracket	4	10-1.5mm x 30mm Hex Bolts
1	Passenger/right Frame Mounting Bracket	8	10-1.5mm x 25mm Button Head Bolts
1	Driver/left Top Bracket	26	10.5mm x 25mm OD x 2mm Flat Washers
1	Passenger/right Top Bracket	14	10mm Lock Washers
2	Tube Spacers	12	10-1.5mm Hex Nuts
4	Spacer Plates	2	8-1.25mm x 25mm Hex Bolts
2	12-1.75mm x 100mm Double Bolt Plates	4	8.4mm x 22mm OD x 1.5mm Flat Washers
4	12.5mm x 30mm OD x 2mm Flat Washers	2	8mm Lock Washers
4	12mm Lock Washers	2	8-1.25mm Hex Nuts
4	12-1.75mm Hex Nuts	1	6mm Allen Wrench

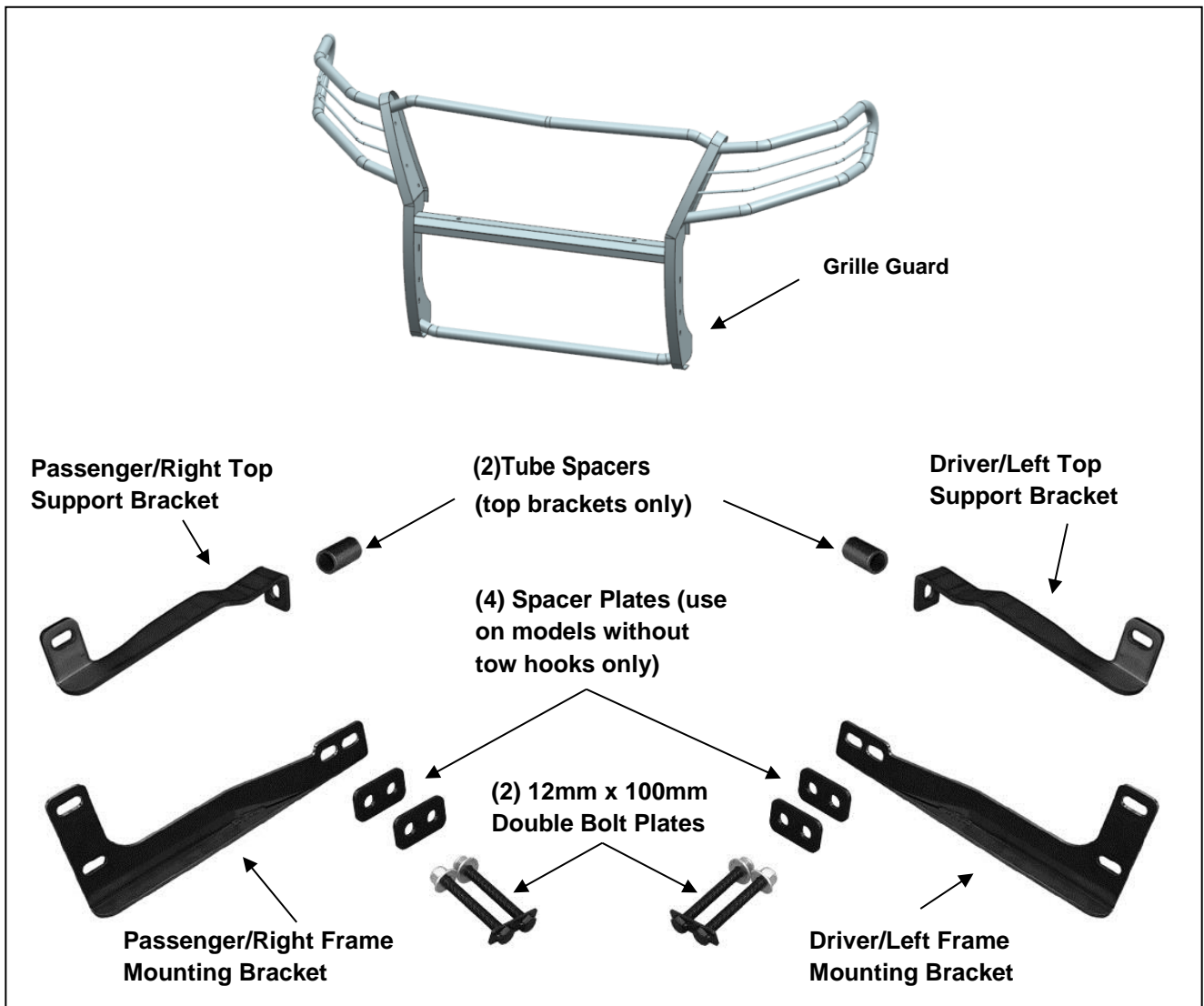

INSTALLATION PROCEDURE:

ASSISTANCE IS RECOMMENDED. CUTTING IS REQUIRED. INSTALLATION MAY INTERFERE WITH FRONT MOUNTED SENSORS.

1. Start installation from under the front of the vehicle. Remove the plastic splash guard from below-behind bumper, **(Figure 1)**. Also, it may be necessary to temporarily remove the factory skid plate, (if equipped), to access the mounting locations. With assistance, remove the plastic front bumper cover, **(Figures 2A—2D)**. Move the cover to clean area to avoid damage to the finish.
2. Remove the top outer bumper bolt from the passenger side, **(Figure 3)**. Select the passenger side Top Bracket, **(Figure 5)**. Hold the Bracket up in place against the bottom of the plastic air deflector. Use removable tape to mark the location of the bracket against the air deflector, **(Figure 4)**. Use a sharp knife or hacksaw blade to cut the deflector to clear the top Bracket. Only remove enough of the plastic to clear the Bracket, **(Figure 6)**.
3. Next, insert (1) 10mm x 80mm Hex Bolt, (1) 10mm Lock Washer and (1) 10mm Flat Washer through the passenger side Top Bracket. Slide (1) Tube Spacer over the threaded end of the Hex Bolt, **(Figure 5)**. Insert the Top Bracket assembly, Tube Spacer first, into the opening in the front of the bumper, **(Figure 6)**. Snug but do not tighten hardware at this time.
4. Repeat **Steps 2 & 3** to install the driver side Top Bracket assembly.
5. Next, determine if the vehicle is equipped with tow hooks.

Models without tow hooks:

- a. Openings in the bumper cover must be cut out to clear the Frame Brackets. Cut along the factory cut lines molded into both pockets in the cover, **(Figures 7 & 8)**. Additional trimming may be required for Frame Bracket clearance.
- b. Select the passenger side Frame Bracket, 12mm Double Bolt Plate and (2) Spacers, **(Figures 9 & 10)**. Insert the Bolt Plate from the inside out through the frame. Slide the (2) Spacers over the threaded end of the Bolt Plate, **(Figures 10 & 11)**. Slide the Bracket over the Bolt Plate and Spacers, (with Spacers between frame and Bracket), and attach with (2) 12mm Flat Washers and (2) 12mm Nylon Lock Nuts, **(Figure 12)**. Do not fully tighten hardware at this time.
- c. Repeat to install the driver side frame Bracket.

Models with tow hooks:

- a. Remove both tow hooks and seals around tow hooks, **(Figure 8)**.
 - b. Replace the factory tow hook hardware with the included longer 12mm Double Bolt Plate, **(Figures 10 & 13)**. Reinstall the tow hook over the frame. Insert the 12mm Double Bolt Plate through the tow hook and frame, **(Figure 13)**. Slide the Bracket over the Bolt Plate and secure the Bracket to the tow hook with (2) 12mm Flat Washers and (2) 12mm Nylon Lock Nuts. Do not fully tighten hardware at this time. **NOTE:** Spacers are not required when reinstalling the tow hooks.
 - c. Repeat to install the driver side Frame Bracket.
6. With assistance, hold the Grille Guard up in position on the outside of the Mounting Brackets. Bolt the Grille Guard to the Brackets with (4) 10mm x 30mm Hex Bolts, (8) 10mm Flat Washers and (4) 10mm Nylon Lock Nuts, **(Figure 14)**. Do not tighten hardware at this time.
 7. Attach the passenger side Top Bracket to the Grille Guard with (1) 8mm x 30mm Hex Bolt, (2) 8mm Flat Washers and (1) 8mm Nylon Lock Nut, **(Figure 15)**. Snug but do not fully tighten hardware at this time. Repeat this Step to attach the driver side Top Bracket.
 8. Check the Grille Guard side to side alignment with the vehicle. Align and adjust as required then fully tighten only the long bolts attaching the Top Brackets to the steel inner bumper. **IMPORTANT:** The (2) Hex Bolts attaching the Top Brackets to the steel bumper cannot be accessed with plastic bumper cover in place. Align-adjust the position of the Grille Guard before tightening the 10mm Hex Bolts.
 9. Temporarily remove the Grille Guard. On some models, the plastic bumper cover can be reinstalled with the top and frame brackets in place. If there are any fitment difficulties, temporarily remove only the lower Frame Brackets. Reinstall the bumper cover. Reinstall the Frame Mounting Brackets, (if removed). Reinstall the Grille Guard as described in **Steps 6 & 7**.
 10. Reinstall the plastic splash guard and/or skid plate removed in **Step 1, (Figure 1)**.
 11. Align and adjust the Grille Guard and fully tighten all hardware.
 12. Do periodic inspections to the installation to make sure that all hardware is secure and tight.

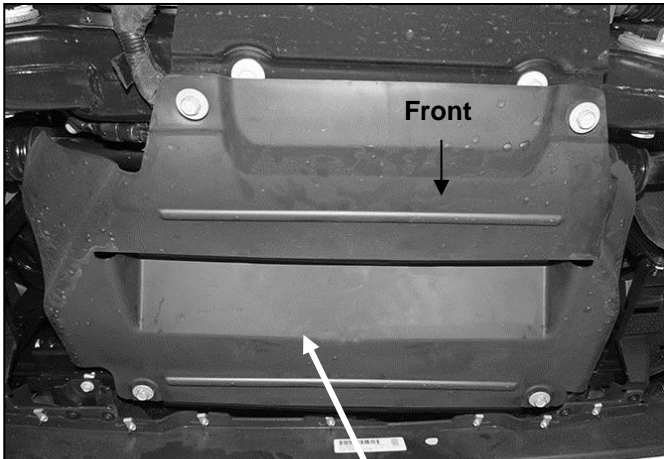

(Fig 1) Remove splash guard or skid plate from bottom of engine behind bumper

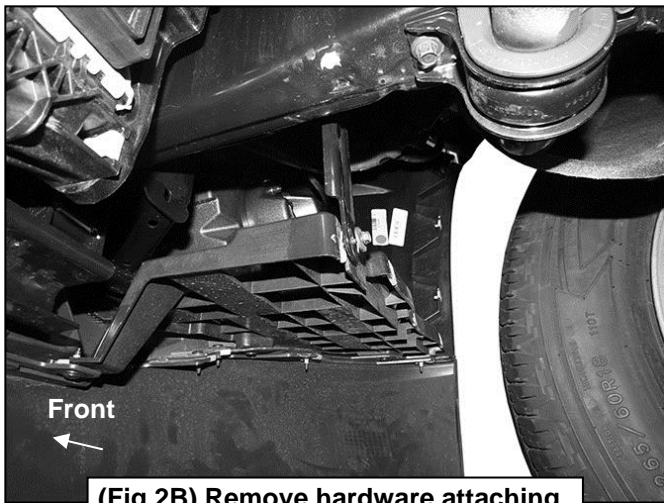

(Fig 2B) Remove hardware attaching plastic fill panel to inner fender

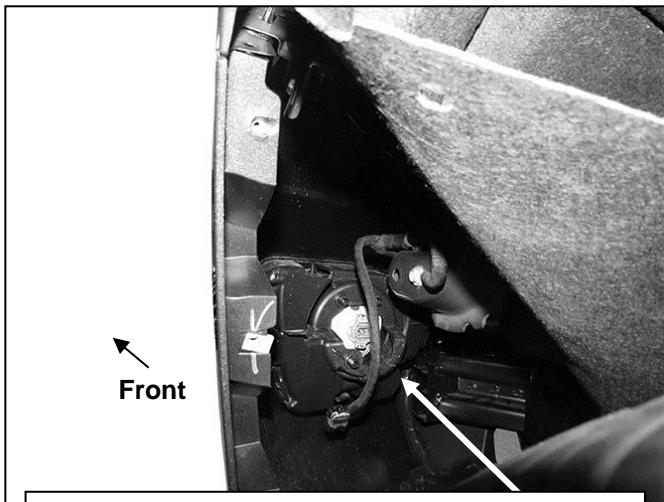

(Fig 2C) Pull back fender liner to access bumper hardware and unplug light if equipped

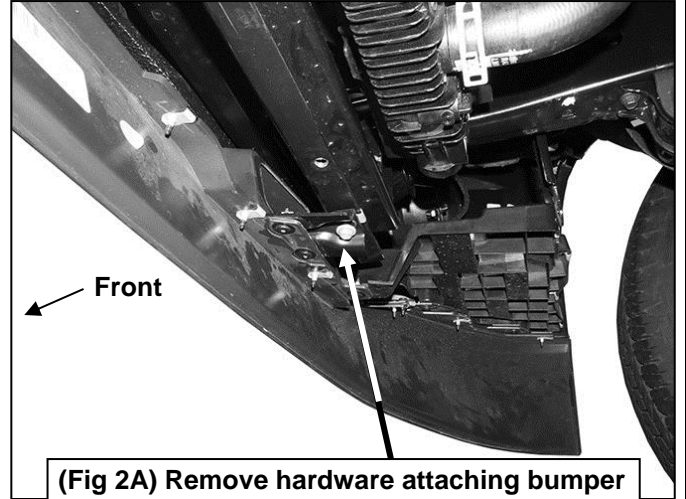

(Fig 2A) Remove hardware attaching bumper cover to cross member behind bumper



(Fig 2C) Remove hardware attaching fender liner to bumper cover

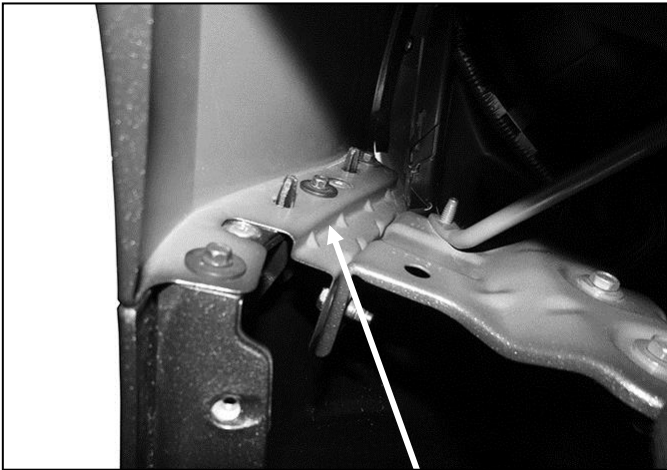

(Fig 2D) Remove hardware attaching bumper cover to fender. Remove bumper cover



(Fig 4) Hold Top Bracket in place to determine area to cut from air deflector

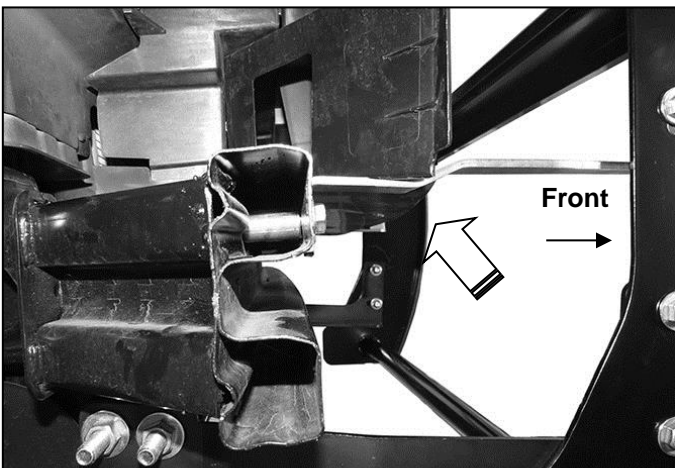

**(Fig 6) Air deflector cut to clear Top Bracket
(NOTE: Grille Guard installed to align Top Brackets before tightening 10mm x 80mm Hex Bolts)**

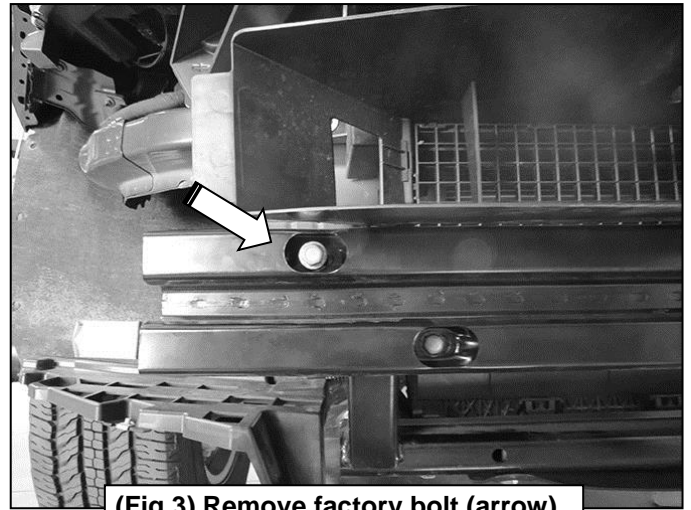

(Fig 3) Remove factory bolt (arrow).

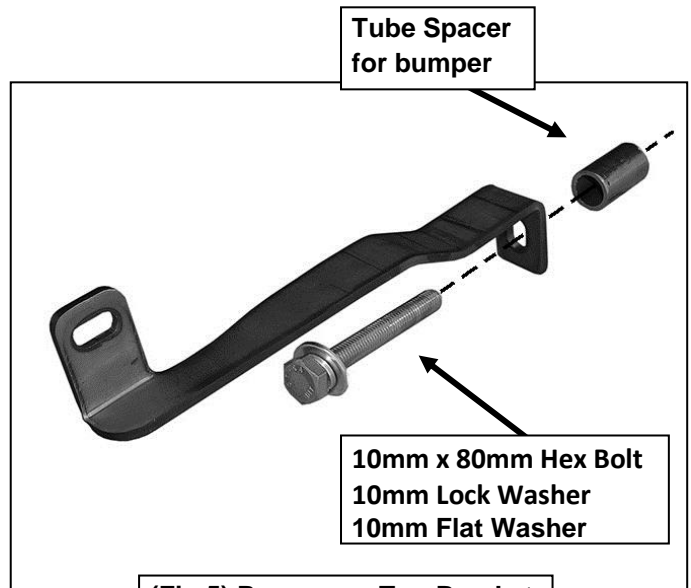

(Fig 5) Passenger Top Bracket

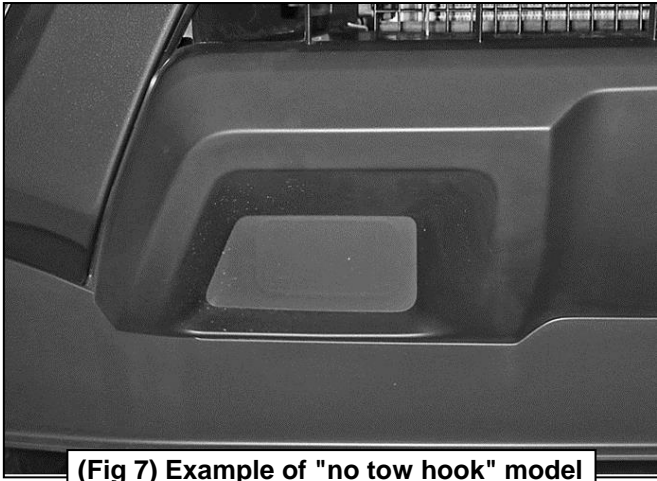

(Fig 7) Example of "no tow hook" model



(Fig 8) Cut opening to clear Bracket

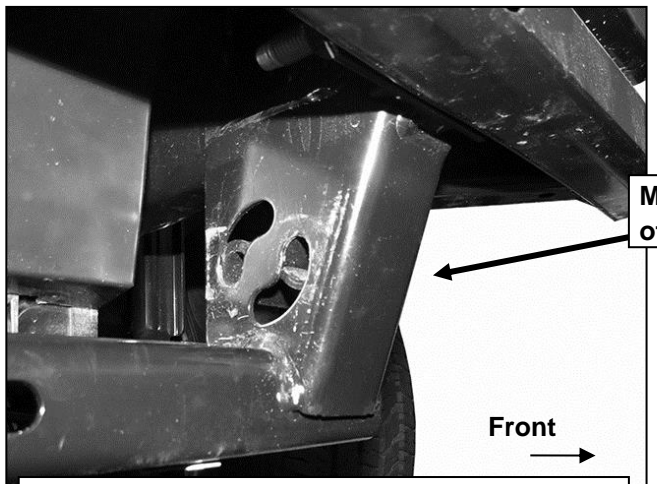

Mounting holes in end of frame for tow hook

(Fig 9) Driver side tow hook mounting location

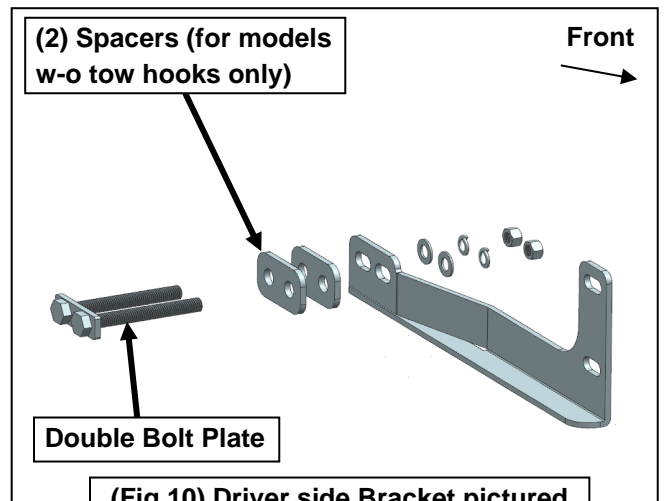

(2) Spacers (for models w-o tow hooks only)

Double Bolt Plate

(Fig 10) Driver side Bracket pictured

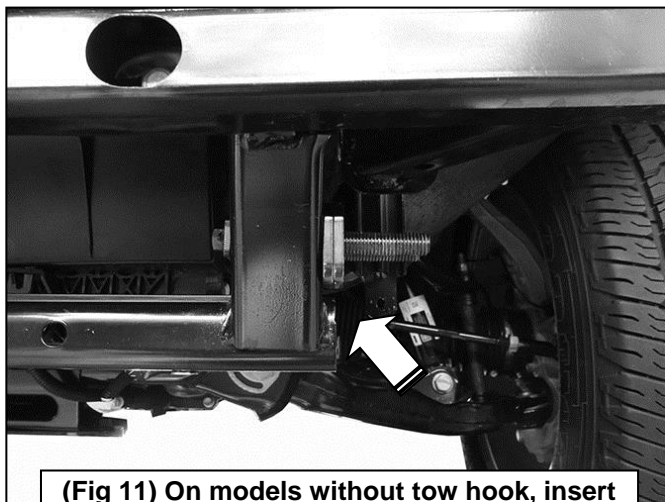

(Fig 11) On models without tow hook, insert (2) Spacers between Bracket and frame

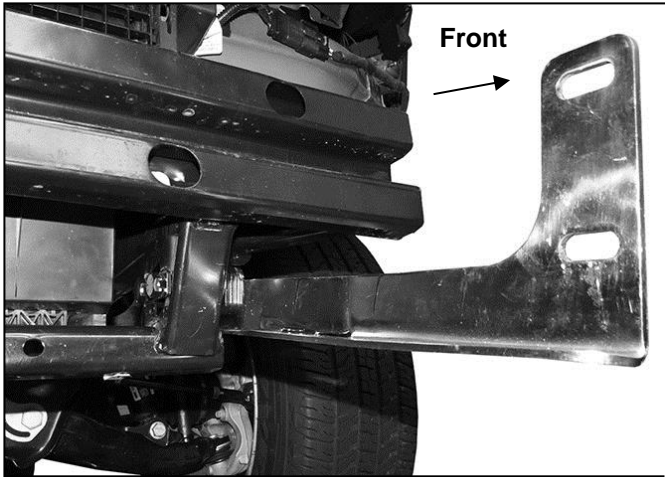

(Fig 12) Driver side Bracket installed over spacers

- (2) 10mm x 30mm Hex Bolts
- (4) 10mm Flat Washers
- (2) 10mm Lock Washers
- (2) 10mm Hex Nuts

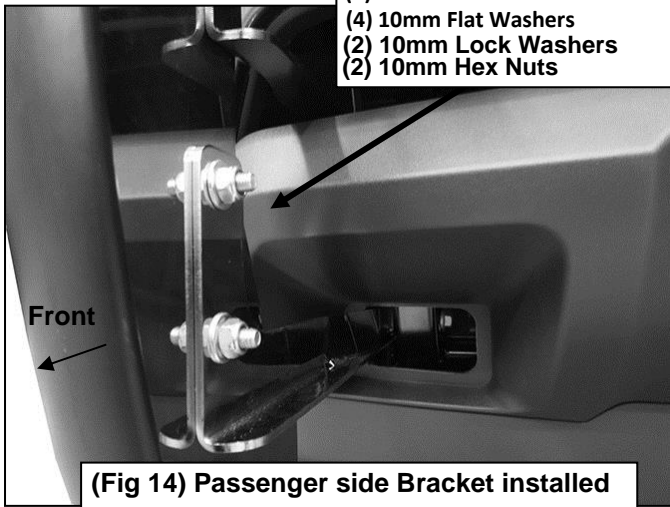

(Fig 14) Passenger side Bracket installed through opening in bumper cover

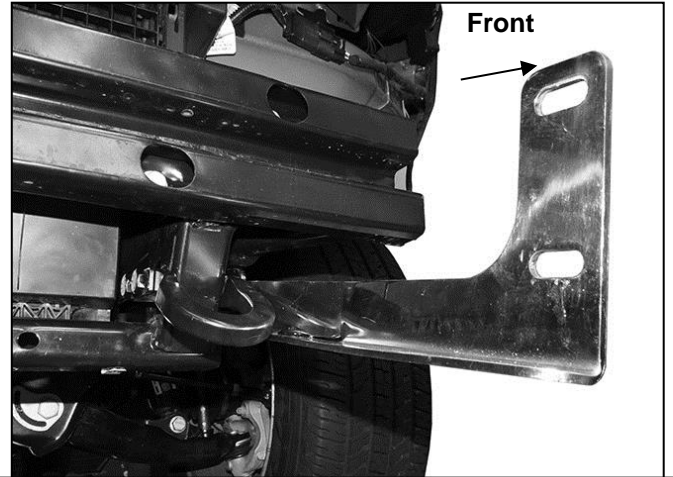

(Fig 13) Driver side Bracket installed over tow hook, Spacers are not required. Installation pictured without bumper for instruction purposes only

- 8mm x 25mm Hex Bolt
- (2) 8mm Flat Washers
- 8mm Lock Washers
- 8mm Hex Nuts



(Fig 15) Attach Top Bracket to Grille Guard



Complete Installation