









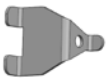

# INSTALLATION MANUAL

**PRODUCT NAME: Front Bumper for 21+ Ford Bronco**

## 1、NOTICE:

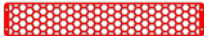
- For the convenience of installation, please read the goods manual carefully before installation; When installation, please pay attention to protect your car's surface, and avoid scratches.
- Please check all the accessories connected to the car whether loose or not, and ensure the security. Clean the side bar regular to keep it clean.
- All the pictures in this manual are only for reference, the picture and material object may have different, but the installation method is the same.

## 2、PART LIST

NO.	Description	QTY	SIZE	NO.	Description	QTY	SIZE
①	Bar	1		⑦	Bracket (right)	1	
②	Middle Plate	1		⑧	Radar Bracket	4	
③	Guardrail	1		⑨	ACC Bracket	1	
④	Winch Frame	1		⑩	Lamp grill 1	1	
⑤	Bracket (up)	1		⑪	Lamp grill 2	2	
⑥	Bracket (left)	1					
REMARK: The same installation for both bracket							

NO.	Description	QTY	SIZE	NO.	Description	QTY	SIZE
A、	Hardware 1	1		⑬	Hex Bolt	8	M12*50
⑫	Hex Bolt	5	M10*35	⑭	Hex Bolt	8	M12*40
⑬	Flat Washer	10	D10*30	⑮	Flat Washer	32	D12*30

⑭	Spring Washer	5	D10	⑲	Spring Washer	16	D12
⑮	Hex Nut	5	M10	⑳	Hex Nut	16	M12

NO.	Description	QTY	SIZE	NO.	Description	QTY	SIZE
B、	Hardware 2	1		⑳	Hexagon head flange toothed nut	4	M8
㉑	Hex Bolt	2	M10*25*1.25	㉒	Hexagon Socket Head Bolt	24	M6*16
㉓	Flat Washer	2	D10*30	㉔	Flat Washer	12	D6*18
㉕	Spring Washer	2	D10	㉖	Hexagon head flange toothed nut	20	M6
㉗	Hexagon Socket Head Bolt	4	M8*20	㉘	Caliper Nut	4	M6
㉙	Flat Washer	4	D8*20				

### 3、INSTALLATION MAP

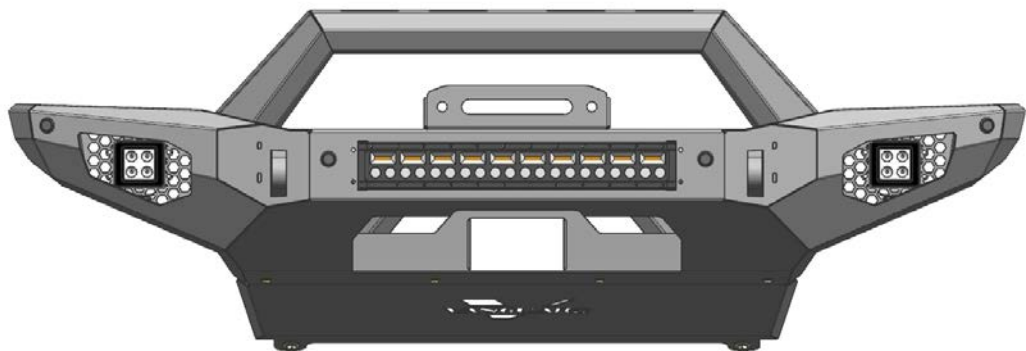

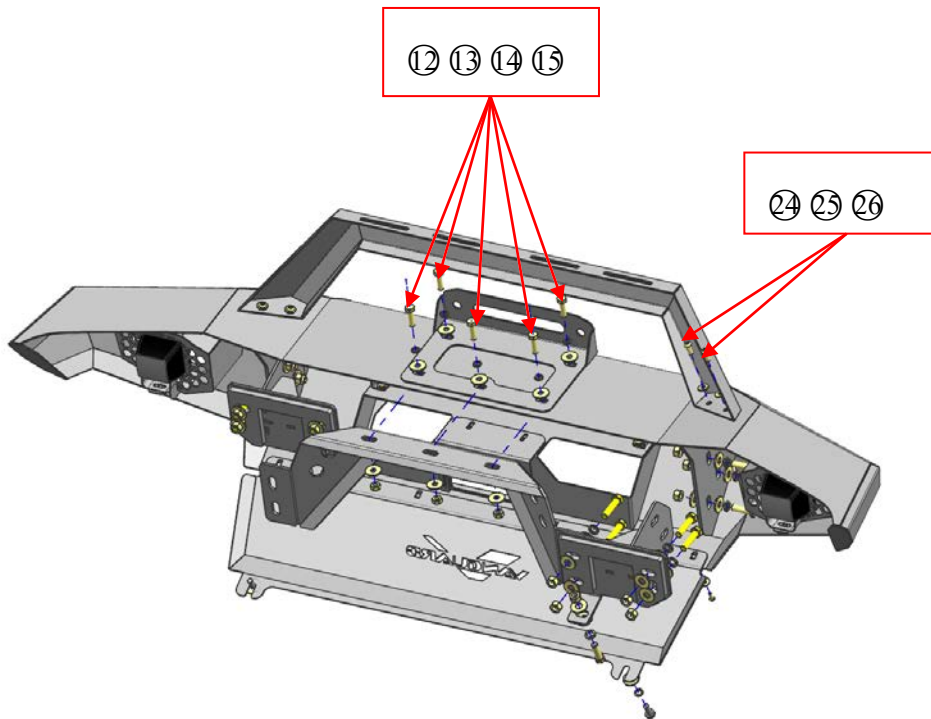
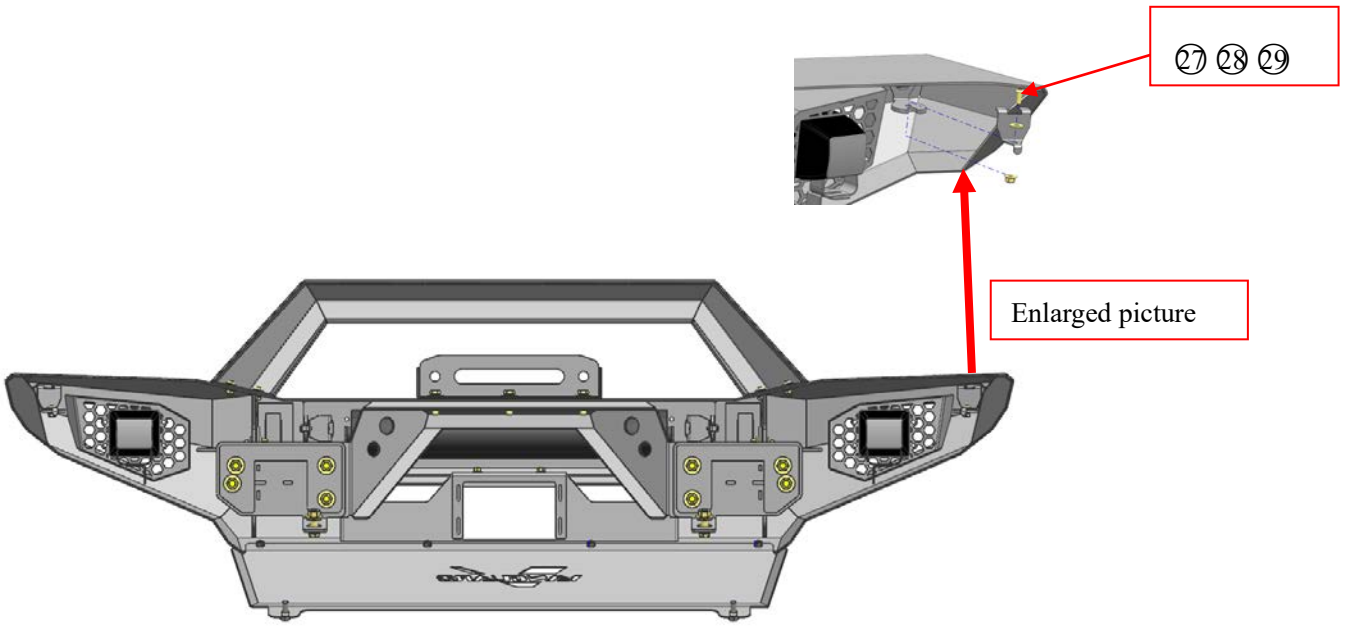

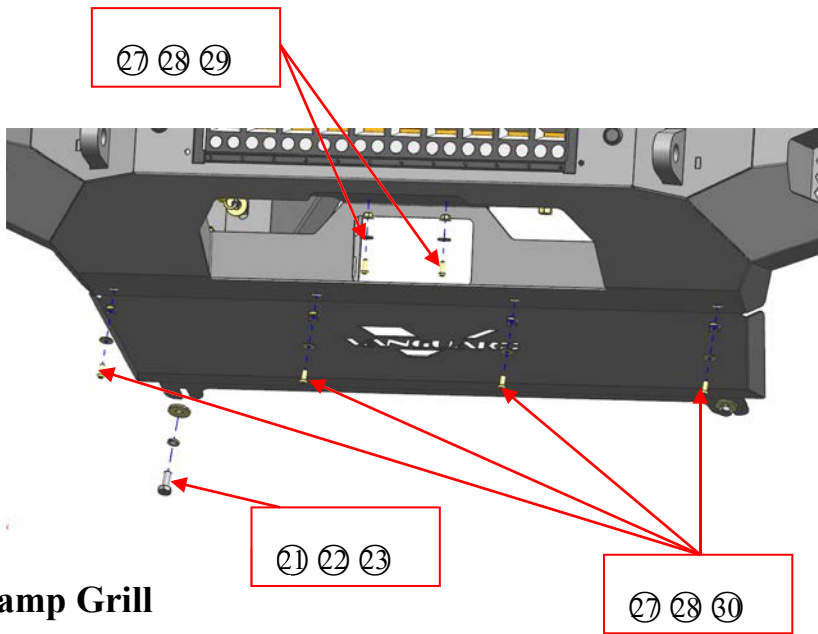
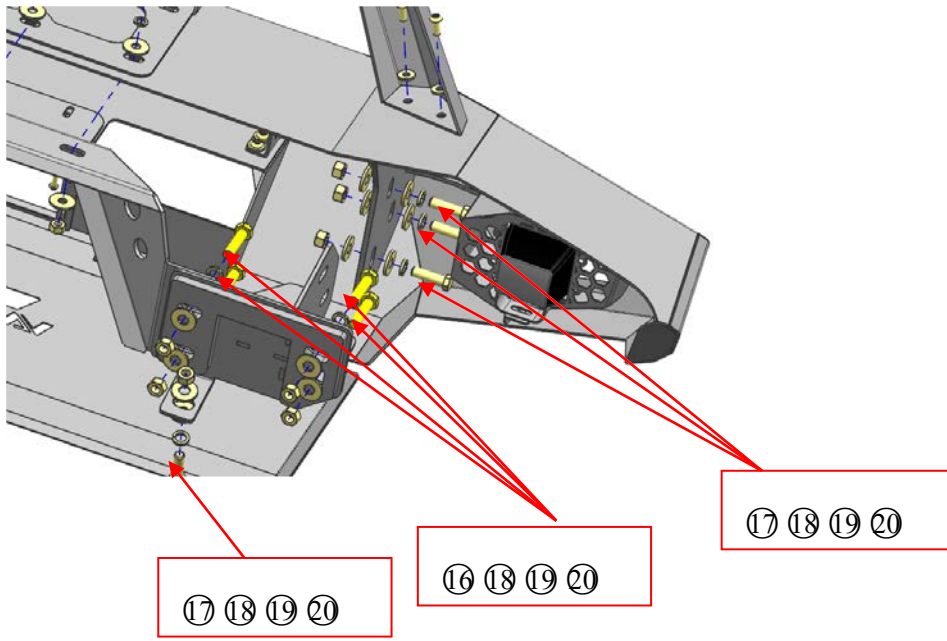

**Fitting Lamp Grill**

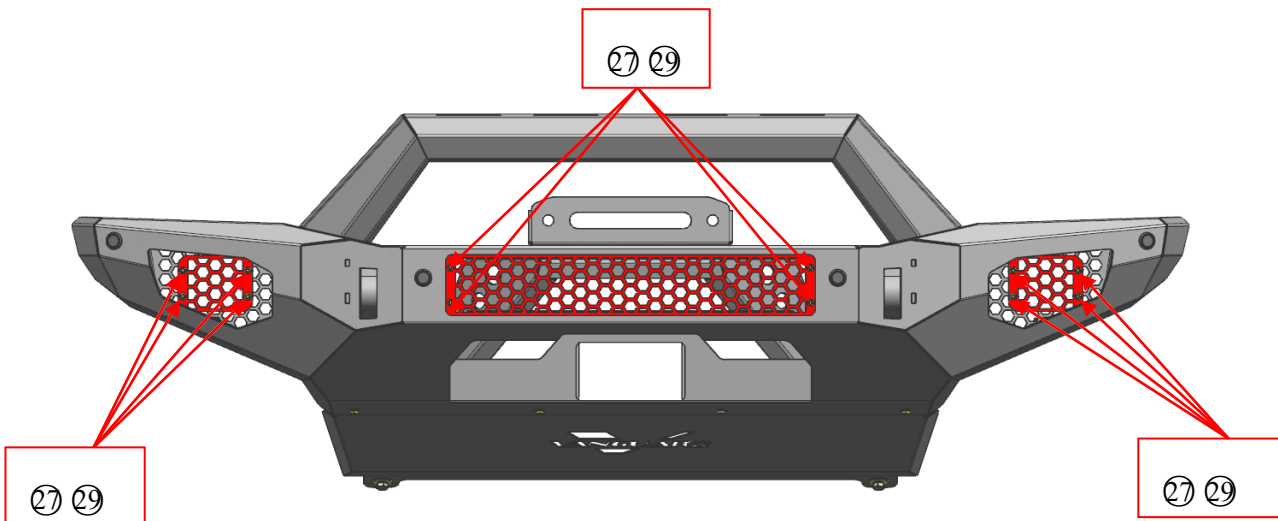

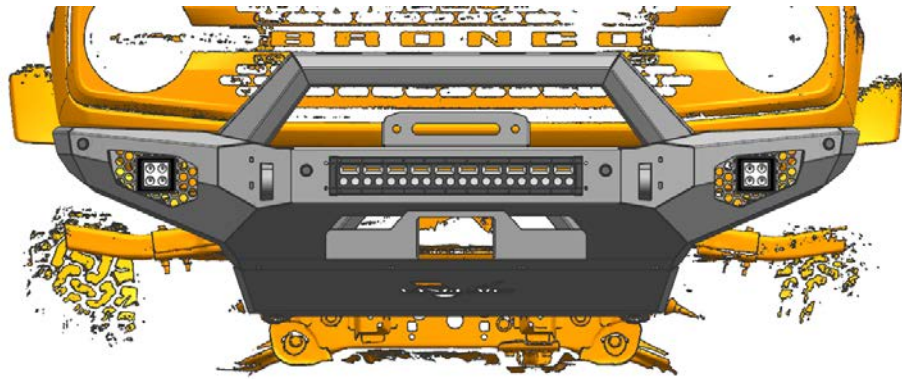

Winch Frame Install

Skid Plate Install

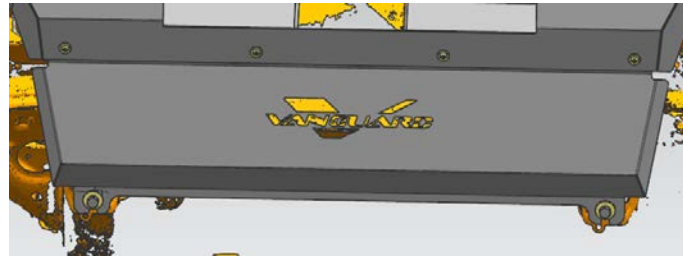
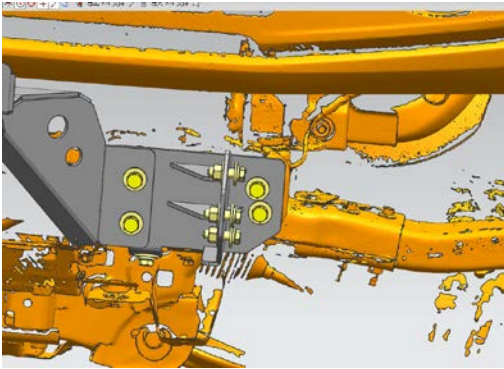

#### 4、INSTALLATION PROCEDURE:

Step 1: Refer to the parts list and parts diagram and check accessories are complete or not.

Step 2: For the quickly of installation, according with bracket installation map distinguishes left and right, then tight the bracket is finished.

Step 3: Remove the Mud from bottom, fixing the bracket on the bottom.

Step 4: Double check the accessories are complete and tighten.

5、Disclaimer: Caused due to improper installation initiates some related problem and losses, are beyond our company's quality assurance.