

**PARTS LIST:**

1	Driver/Left Running Board	4	12mm x 32mm x 3mm Flat Washers
1	Passenger/Right Running Board	4	12mm Lock Washers
1	Driver/Left Front Mounting Bracket	4	12mm Hex Nuts
1	Passenger/Right Front Mounting Bracket	4	10mm x 30mm Hex Bolts
1	Driver/Left Front Support Bracket	2	10mm x 27mm OD x 3mm Flat Washers
1	Passenger/Right Front Support Bracket	8	10mm x 20mm OD x 2mm Flat Washers
2	Center Mounting Brackets	6	10mm Lock Washers
2	Center Bracket Arms	6	10mm Hex Nuts
2	Center Bracket Clamps	10	8mm x 25mm Carriage Bolts
1	Driver/Left Rear Mounting Bracket	4	8mm x 25mm Hex Bolts
1	Passenger/Right Rear Mounting Bracket	12	8mm x 22mm OD x 2mm Flat Washers
2	Rear Support Brackets	2	8mm x 16mm OD x 1.6mm Flat Washers
1	8mm Threaded Insert Tool	4	8mm Lock Washers
4	8mm Threaded Inserts	10	8mm Nylon Locking Nuts
2	12mm x 40mm Long Bolt Plates	12	6mm x 20mm T-Bolts
2	12mm x 35mm Button Head T-Bolt Plates	12	6mm x 22mm x 2mm Flat Washers
2	10mm x 35 Long Bolt Plates	12	6mm Lock Washers
		12	6mm Hex Nuts

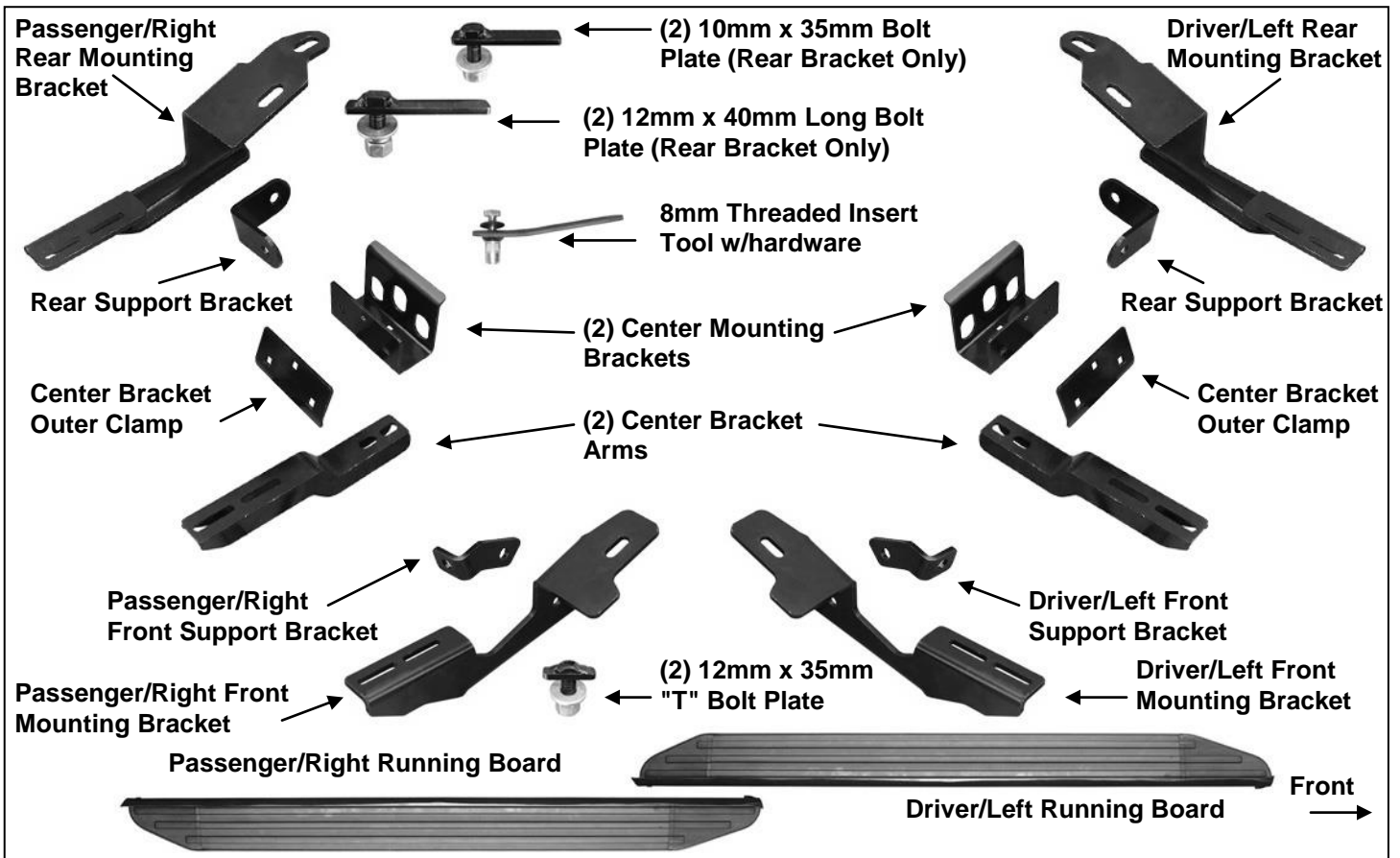

**PROCEDURE:**

1. REMOVE CONTENTS FROM BOX. VERIFY ALL PARTS ARE PRESENT. READ INSTRUCTIONS CAREFULLY BEFORE STARTING INSTALLATION. DRILLING IS REQUIRED. ASSISTANCE IS RECOMMENDED.

2. Start installation under the driver side of the vehicle. Select (1) 12mm x 35mm Small T-Bolt Plate and insert it into the factory oval hole in the floor panel, **(Figures 1A & 1B)**. Rotate the Bolt Plate 90-degrees so that the plate is across the oval hole. Select the driver side front Mounting Bracket. Hang the Bracket from the Bolt Plate with (1) 12mm Flat Washer, (1) 12mm Lock Washer and (1) 12mm Hex Nut, **(Figure 2)**. **NOTE:** Make sure that the mounting flange on the front Bracket is lined up properly with the indent in the floor panel. The front Mounting Bracket must sit flat against the floor panel. Do not tighten hardware at this time.
3. Select the driver side front Support Bracket, **(Figure 3A)**. Bolt the Support Bracket to the back of the front Bracket with (1) 10mm x 30mm Hex Bolt, (2) 10mm x 20mm STD Flat Washers, (1) 10mm Lock Washer and (1) 10mm Hex Nut, **(Figure 3B)**. Line up the mounting tab on the Support Bracket with the back of the pinch weld. Do not tighten hardware at this time.
4. Select (1) center Mounting Bracket, Clamp and Arm. Bolt the Arm to the bottom of the center Bracket with (2) 8mm Carriage Bolts, (1) 8mm x 22mm Large Flat Washer (outer), (1) 8mm x 16mm STD Flat Washer (inner), and (2) 8mm Nylon Lock Nuts, **(Figure 4)**.
5. Bolt the Clamp Plate to the outside of the center Bracket with (2) 8mm Carriage Bolts (insert through Plate and the Bracket), (2) 8mm x 22mm Large Flat Washers and (2) 8mm Nylon Lock Nuts, **(Figure 5)**. Do not tighten hardware at this time.
6. **IMPORTANT:** Select a location for the center Bracket along the pinch weld, mid way between the front and rear Brackets where the seam is as flat as possible, **(Figure 6)**. Do not install the Bracket over any of the drip channels in the pinch weld. Once an appropriate location has been found, slide the outer Clamp Plate and Bracket over the pinch weld with the back part of the Bracket tight against the floor panel, **(Figure 7)**. Tighten the (2) 10mm Lock Nuts to tighten the Clamp on the pinch weld, **(Figure 8)**. Do not fully tighten at this time.
7. Move toward the rear location. Locate the oval and round holes in the floor panel toward the rear of the vehicle, **(Figure 9A)**. Insert (1) 10mm x 35mm Bolt Plate into the round hole, **(Figure 9B)**. Insert (1) 12mm x 40mm Long Bolt Plate into the oval hole next to the pinch weld, **(Figure 9C)**. Rotate the 12mm Bolt Plate 90-degrees so that the plate is across the oval hole.
8. Position the Rear Mounting Bracket over the (2) Bolt Plates. Secure the Bracket to the 12mm Bolt Plate with (1) 12mm Flat Washer, (1) 12mm Lock Washer and (1) 12mm Hex Nut, **(Figure 10B)**. Bolt the Bracket to the 10mm Bolt Plate with (1) 10mm x 27mm OD Large Flat Washer, (1) 10mm Lock Washer and (1) 10mm Hex Nut. Snug hardware but do not tighten at this time.
9. Next, select (1) "L" rear Support Bracket, **(Figure 10A)**. Bolt the Support Bracket to the front facing side of the rear Mounting Bracket with (1) 10mm x 30mm Hex Bolt, (2) 10mm x 20mm STD Flat Washers and (1) 10mm Nylon Lock Nut, **(Figures 10B)**. Do not tighten hardware at this time.
10. Select the driver side Running Board. From the front end of the Board, slide (3) 6mm T-Bolts into each channel on the bottom of the Board, **(Figure 11)**. Slide the T-Bolts into place in line with the (3) Brackets and place the Board onto the Brackets. Attach the T-Bolts to the Brackets with (6) 6mm Flat Washers, (6) 6mm Lock Washers and (6) 6mm Hex Nuts. Snug but do not tighten hardware.
11. Level and adjust the Running Board and tighten the Bracket to Bolt Plate hardware only. **IMPORTANT:** Do not tighten the front and rear Support Bracket hardware at this time.
12. Return to the driver side front Bracket and Support Bracket. Hold the front Support Bracket firmly against the back of the pinch weld. Mark the mounting hole location onto the back of the pinch weld, **(Figure 12)**.
13. Check the Sidebar for level before proceeding. Carefully drill this location with a **7/16"** drill bit. **CAUTION:** Do not drill the hole too close to the bottom edge of the pinch weld. Remove the driver side Front Support Bracket.

**VERY IMPORTANT!** Be very careful and drill slowly through the pinch weld to avoid damaging the outer rocker panel cover.

**NOTE:** Any cutting or drilling tool may break or shatter. Government regulations require safety glasses & equipment at all times when cutting or drilling.

14. Select (1) 8mm Insert Tool, (1) 8mm Threaded Insert, (1) 8mm x 25mm Hex Bolt and (1) 8mm Flat Washer. Assemble the Threaded Insert Installation Tool as pictured in **Figure 13**. Hold the handle and push the Insert into the drilled hole in the pinch weld. **NOTE:** Insert must fit snug in hole. If necessary, use a small hammer to carefully tap the Insert into the hole until the rim on the insert is flush against the

pinch weld. Firmly hold the tool handle and tighten the Hex Bolt in the Tool to expand the Insert in the hole. Continue until threads are pulled up to the top of the Insert, **(Figures 14 & 17)**. Remove the Tool and hardware. Bolt the Support Bracket to the Threaded Insert with (1) 8mm x 25mm Hex Bolt, (1) 8mm Flat Washer and (1) 8mm Lock Washer, **(Figure 15)**. Tighten hardware at this time.

15. Move to the driver side rear Mounting Bracket. Hold the "L" Support Bracket firmly against the back of the pinch weld. Repeat **Steps 10 - 14** to mark and drill the pinch weld and install the Threaded Insert, **(Figures 16 & 17)**. Reinstall the Support Bracket. Bolt the Support Bracket to the Insert with (1) 8mm x 25mm Hex Bolt, (1) 8mm Flat Washer and (1) 8mm Lock Washer, **(Figure 18)**. Tighten hardware at this time. Tighten the front and rear Bracket hardware only at this time.
16. Move to the center Bracket. Loosen the (2) clamp bolts and push the Bracket assembly up against the floor panel. Mark the location of the mounting hole onto the back of the pinch weld, **(Figure 19)**. Check the Running Board alignment before proceeding. Remove the Running Board and Center Bracket. Drill a **5/16"** hole through the pinch weld at the previous mark. **IMPORTANT:** Do not drill too close to the edge of the pinch weld.
17. Reinstall the center Bracket assembly, **(Figures 20 & 21)**. Line up the outer Clamp Plate with the drilled hole. Pull the plastic cover back a little, **(Figure 21)**, and insert (1) 8mm Carriage Bolt through the center hole in the Outer Clamp Plate, the drilled hole and into the Bracket. **IMPORTANT:** Release the factory plastic clips in the bottom of the plastic rocker cover for easier installation of the 8mm Carriage Bolt, **(Figure 21)**. Secure the Bracket to the center bolt with (1) 8mm Flat Washer and (1) 8mm Nylon Lock Nut, **(Figures 22 & 23)**.
18. Reinstall the Running Board as described in Step 10. Check alignment, adjust as necessary and fully tighten all hardware.
19. Repeat **Steps 2 - 19** for passenger/right Running Board installation.
20. Do periodic inspections to the installation to make sure that all hardware is secure and tight.

**To protect your investment**, wax this product after installing. Regular waxing is recommended to add a protective layer over the finish. Do not use any type of polish or wax that may contain abrasives that could damage the finish.

**For stainless steel:** Aluminum polish may be used to polish small scratches and scuffs on the finish. Mild soap may be used also to clean the Running Board.

### Driver/Left Side Installation Pictured

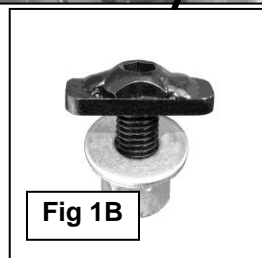
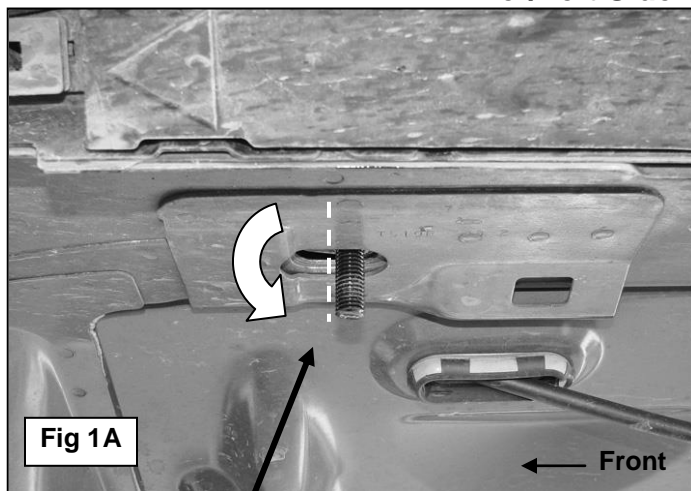

12mm x 35mm T-Bolt Plate  
12mm Flat Washer  
12mm Lock Washer  
12mm Hex Nut

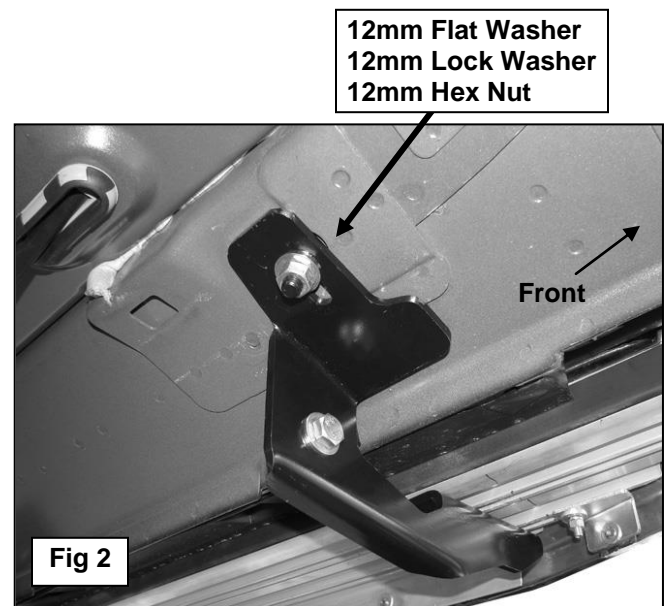

Driver Side Installation Pictured



- 10mm x 30 Hex Bolt
- (2) 10mm x 20mm STD Flat Washers
- 10mm Lock Washer
- 10mm Hex Nut

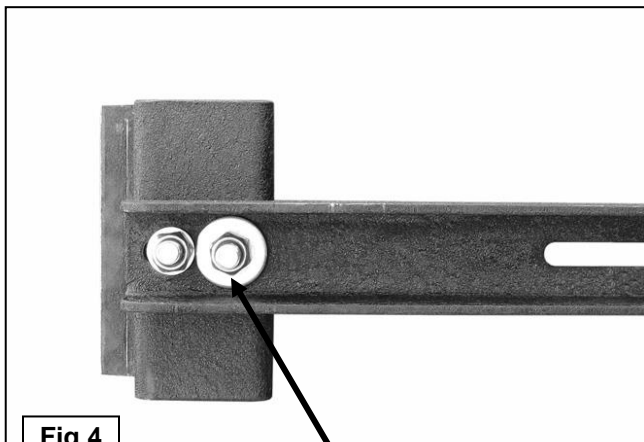
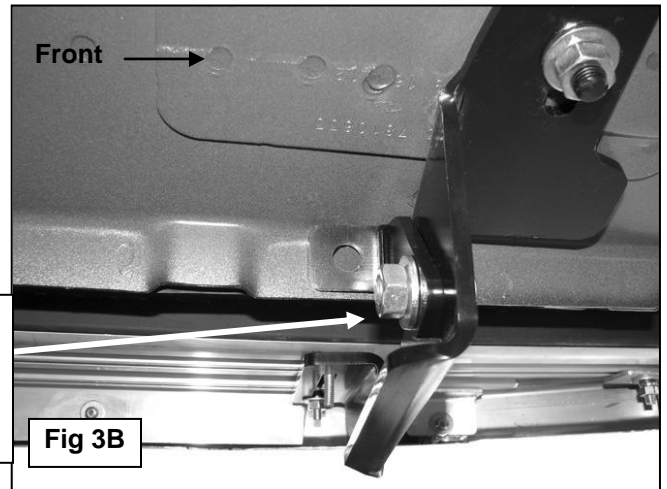

- (2) 8mm x 25mm Carriage Bolts
- 8mm x 16mm STD Flat Washers (inner)
- 8mm x 22mm Large Flat Washers (outer)
- (2) 8mm Nylon Lock Nuts

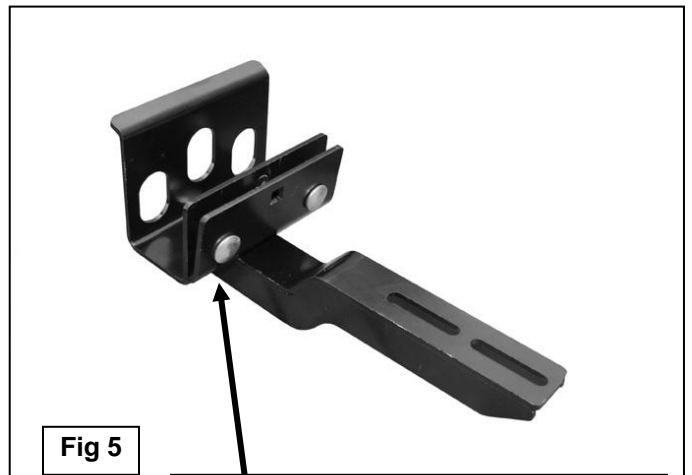

- (2) 8mm x 25mm Carriage Bolts
- (2) 8mm x 22mm Large Flat Washers
- (2) 8mm Nylon Lock Nuts

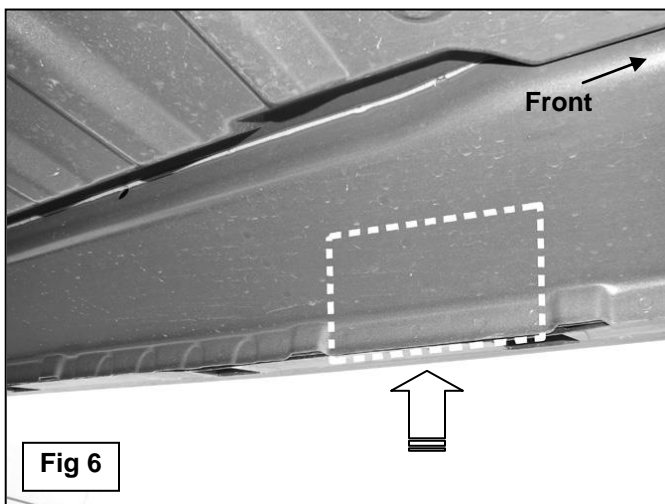

Driver Side Installation Pictured

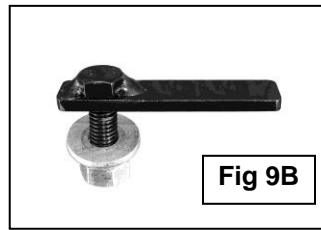
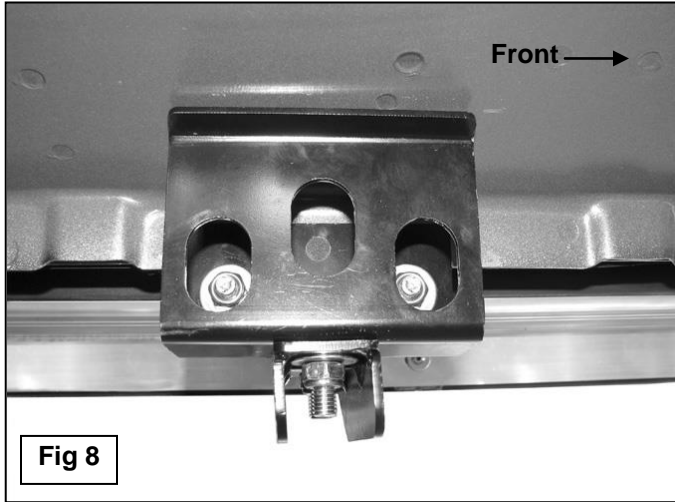

10mm x 35mm Bolt Plate  
10mm Large Flat Washer  
10mm Lock Washer  
10mm Hex Nut

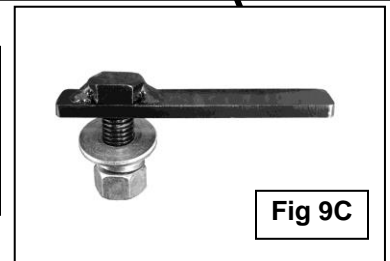
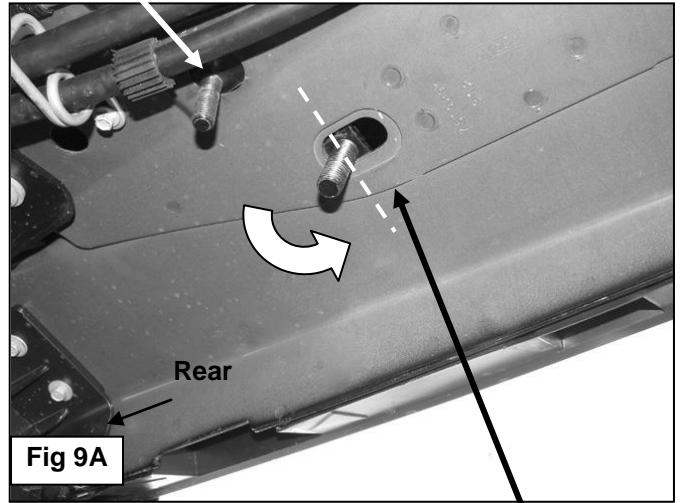
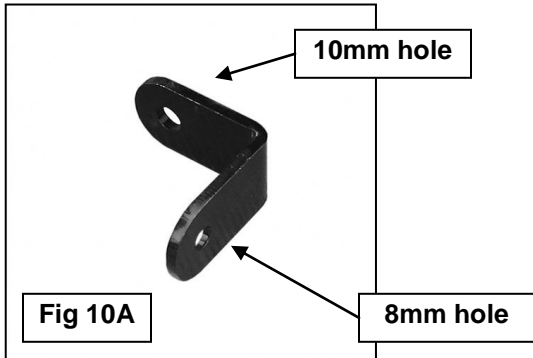

12mm x 40mm Long  
Bolt Plate  
12mm Flat Washer  
12mm Lock Washer  
12mm Hex Nut

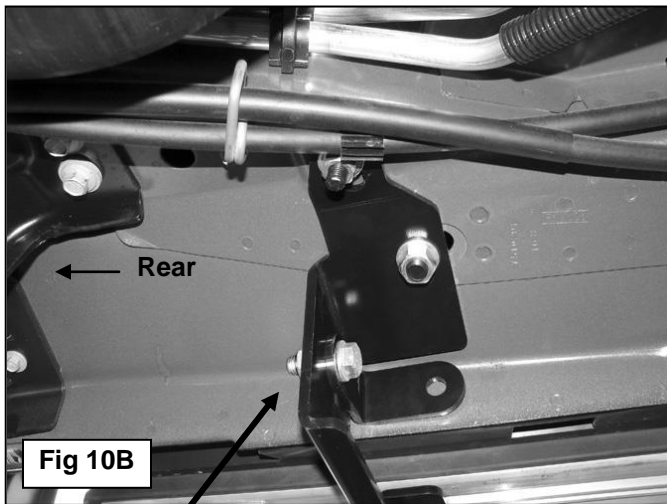

10mm x 30 Hex Bolt  
(2) 10mm Flat Washers  
10mm Nylon Lock Nut

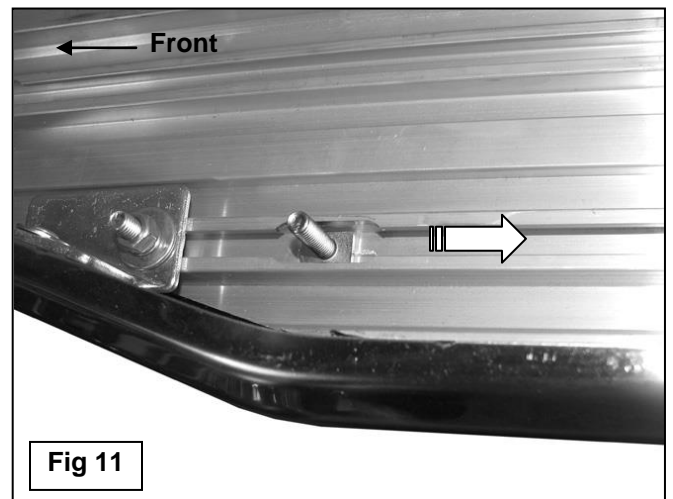

Driver Side Installation Pictured

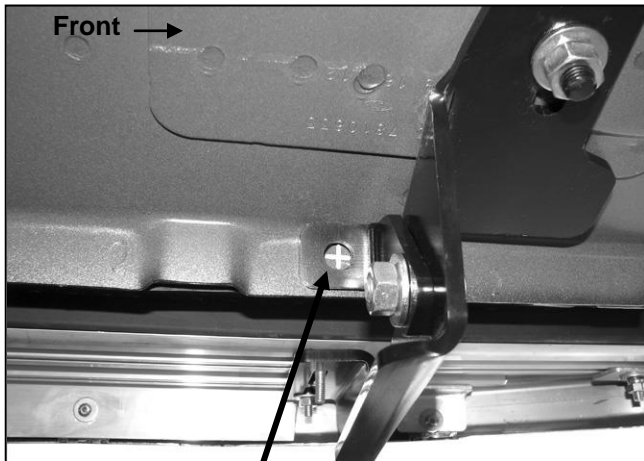

(Fig 12) Mark Support Bracket location onto pinch weld. Carefully drill the location with 7/16" drill bit. Do not drill and install the Insert until after the Sidebar has been completely installed, checked for level and aligned on the vehicle. Repeat procedure to install all Inserts.

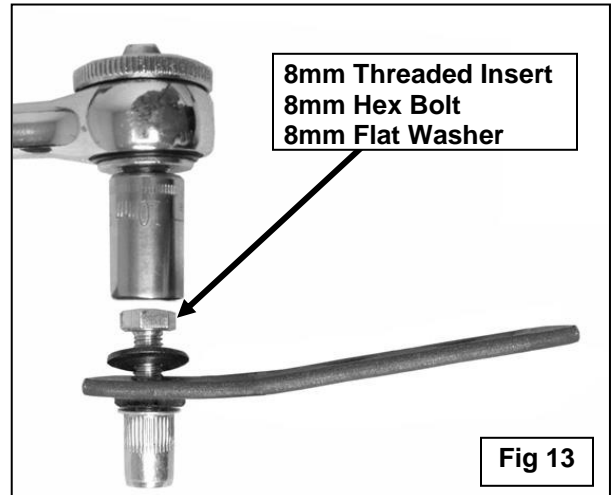
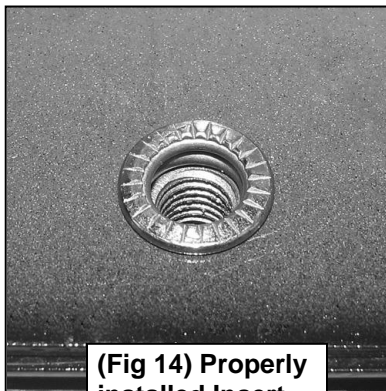

Fig 13



(Fig 14) Properly installed Insert

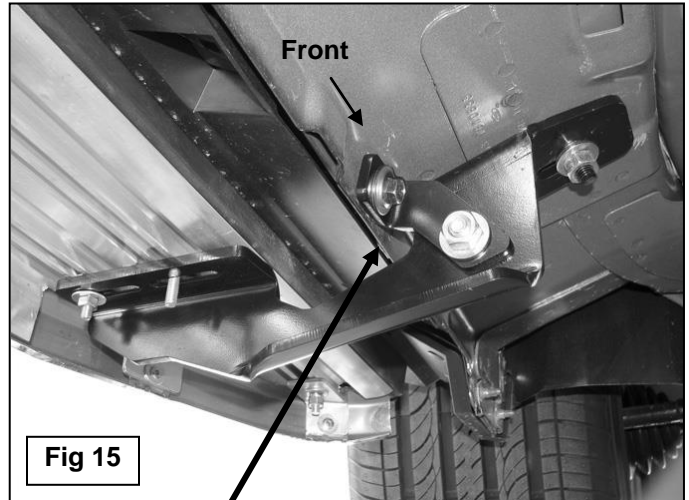
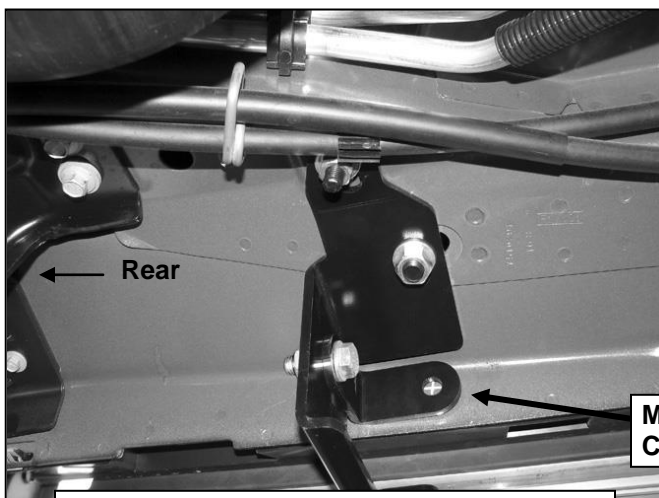

Fig 15

8mm Threaded Insert  
8mm x 25mm Hex Bolt  
8mm Lock Washer  
8mm x 22mm Flat Washer



(Fig 16) Driver side rear Bracket pictured

Mark Support Bracket location onto pinch weld. Carefully drill the location with 7/16" drill bit

Driver Side Installation Pictured

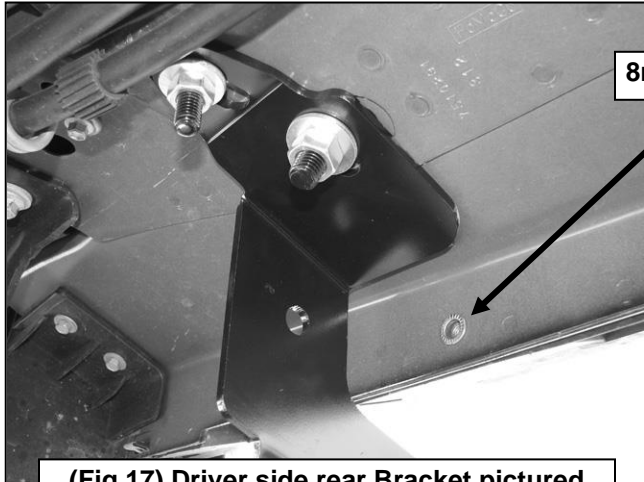

8mm Threaded Insert

(Fig 17) Driver side rear Bracket pictured

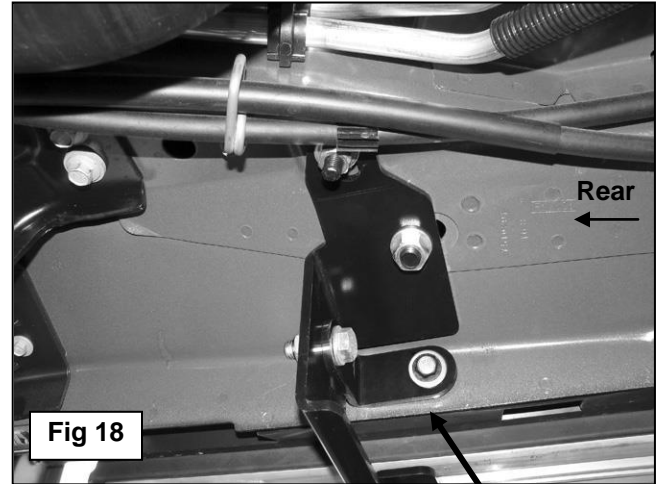
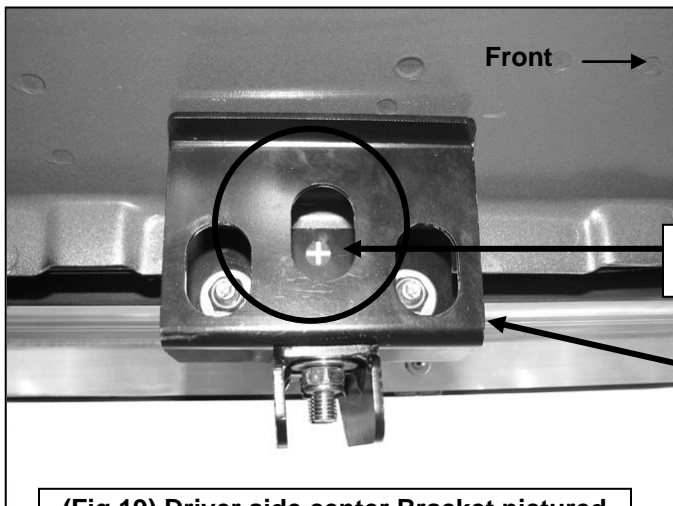

Fig 18

8mm x 25mm Hex Bolt  
8mm Lock Washer  
8mm x 22mm Flat Washer



Mark the Mounting Bracket location onto back of pinch weld. Carefully drill the location with smaller 5/16" drill bit

8mm x 25mm Carriage Bolts  
8mm x 22mm Flat Washers  
8mm Nylon Lock Nuts

(Fig 19) Driver side center Bracket pictured

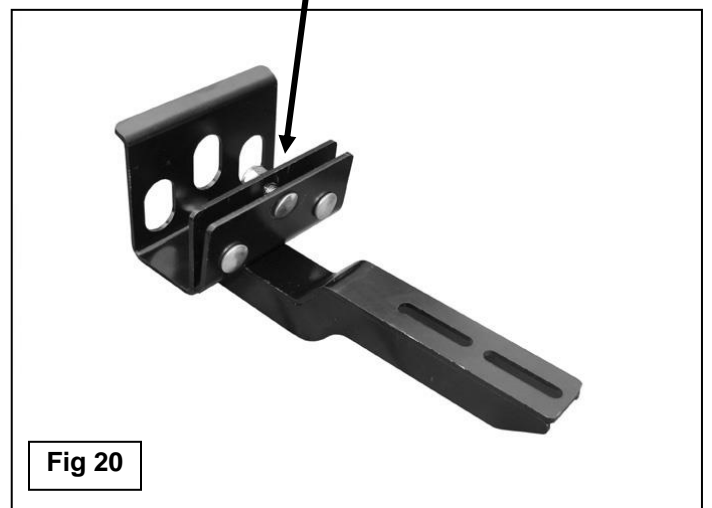

Fig 20

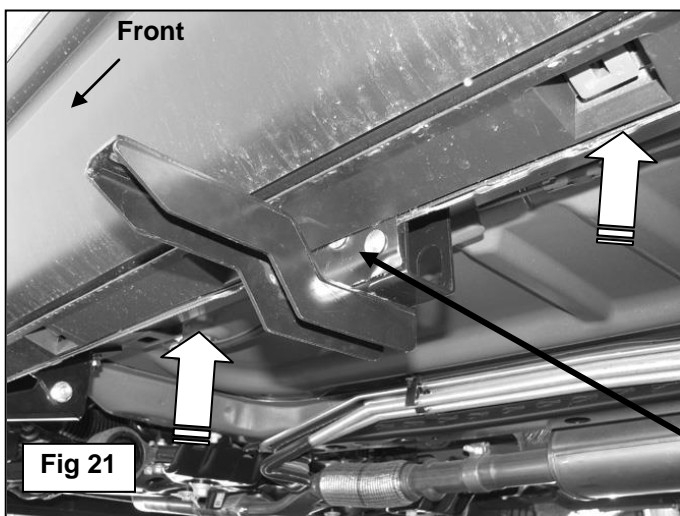
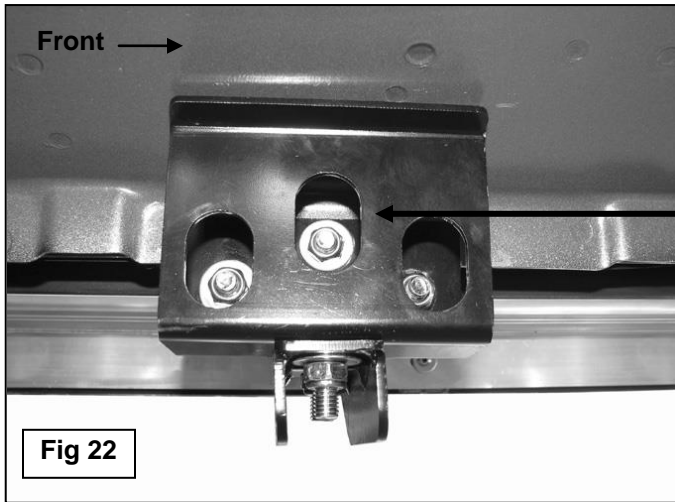

Fig 21

Release clips securing plastic cover to inner rocker panel (see arrows) to insert Carriage Bolt into center (drilled) hole.

Driver Side Installation Pictured



- (3) 8mm x 25mm Carriage Bolts
- (3) 8mm x 22mm Flat Washers
- (3) 8mm Nylon Lock Nuts

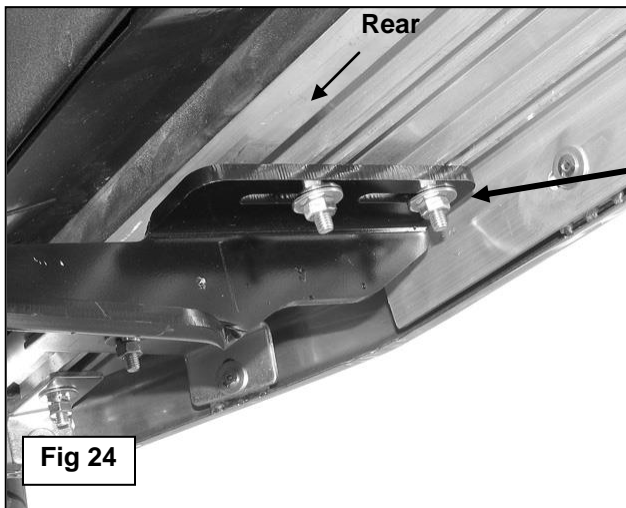
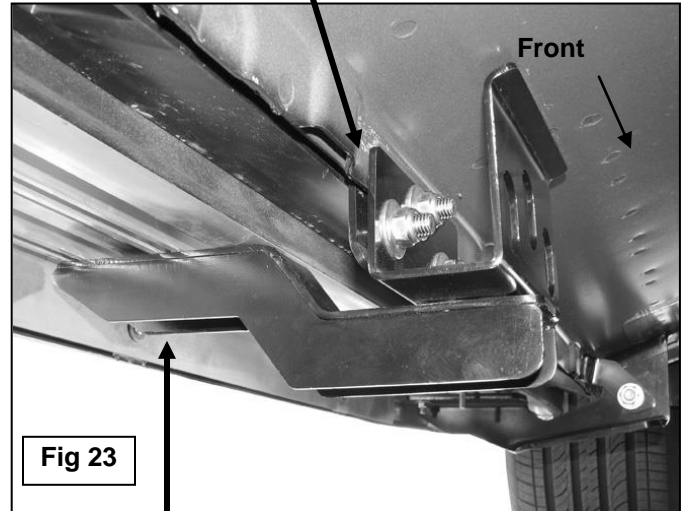

- 6mm T-Bolts
- 6mm Flat Washers
- 6mm Lock Washers
- 6mm Hex Nuts

