



INSTALLATION INSTRUCTIONS

PART # VGUBG-0982SS-20LED

2013-2014 FORD ESCAPE

BULL BAR WITH SKID PLATE

PARTS LIST:

1	2-1/2" Bull Bar	8	12mm x 24mm x 2mm Flat Washers
2	Frame Mounting Brackets	6	12mm Lock Washers
1	Driver/Left Mounting Bracket	4	12mm Hex Nuts
1	Passenger/Right Mounting Bracket	4	8-1.25mm x 70mm x 25mm thread Hex Bolts Gr 8.8
2	12-1.75mm x 50mm Hex Bolts	4	8mm x 22mm x 2mm Flat Washers
4	12-1.75mm x 35mm Hex Bolts	4	8mm Lock Washers
2	12mm x 32mm x 3mm Large Flat Washers		

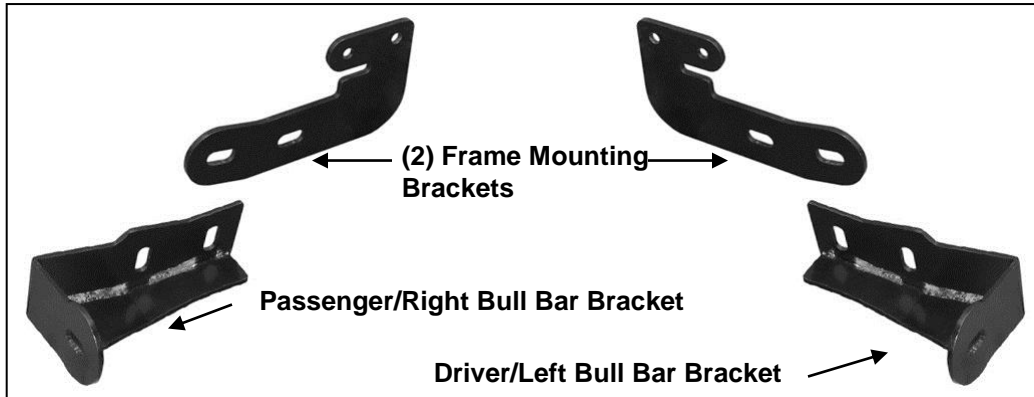

PROCEDURE:

1. REMOVE CONTENTS FROM BOX. VERIFY ALL PARTS ARE PRESENT. READ INSTRUCTIONS CAREFULLY BEFORE STARTING INSTALLATION. ASSISTANCE IS RECOMMENDED.
2. From under the front of the vehicle, remove the large plastic cover under the engine, (Figure 1). Pay close attention to the location of all of the factory hardware for reinstallation.
3. Starting on the driver side, select (1) Frame Mounting Bracket. Locate and remove the two factory hex bolts connecting the subframe, (Figure 2A & 2B). Bolt the Frame Bracket to the side of the subframe with (2) 8mm x 70mm Hex Bolts, (2) 8mm Lock Washers and (2) 8mm Flat Washers, (Figure 3). Tighten Hardware.

IMPORTANT: Install one frame bracket at a time. Do not install the passenger side frame bracket until the driver side frame bracket installation is complete.

4. Select the driver side Mounting Bracket. Bolt the Mounting Bracket to the inside of the Frame Bracket with (2) 12mm x 35mm Hex Bolts, (4) 12mm Flat Washers, (2) 12mm Lock Washers and (2) 12mm Hex Nuts, (Figure 4). Do not tighten hardware at this time.
5. Repeat **Steps 3 – 4** for passenger side Bracket installation.
6. Re-Install the plastic cover with the factory hardware.
7. Carefully un-wrap the Bull Bar. With assistance, hold the Bull Bar up to the Mounting Brackets. Bolt the end of the tubes on the Bull Bar to the Mounting Brackets with the included (2) 12mm x 50mm Hex Bolts, (2) 12mm Lock Washers and (2) 12mm x 32mm Large Flat Washers, (Figure 5). Snug but do not tighten hardware at this time.
8. Level and adjust the Bull Bar and tighten all hardware, (Figure 6).
9. Do periodic inspections to the installation to make sure that all hardware is secure and tight.

To protect your investment, wax this product after installing. Regular waxing is recommended to add a protective layer over the finish. Do not use any type of polish or wax that may contain abrasives that could damage the finish.

For stainless steel: Aluminum polish may be used to polish small scratches and scuffs on the finish. Mild soap may be used also to clean the Bull Bar.

For gloss black finishes: Mild soap may be used to clean the Bull Bar.

Driver Side Installation Pictured

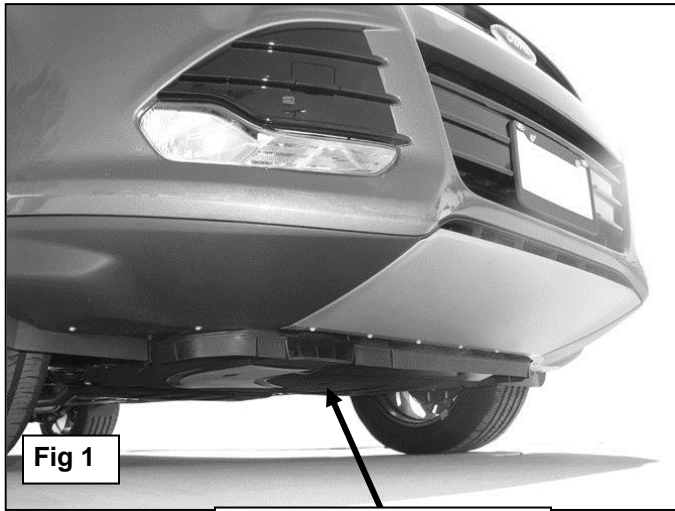

Remove the large plastic cover under the engine

Remove the (2) factory hex bolts from the outside

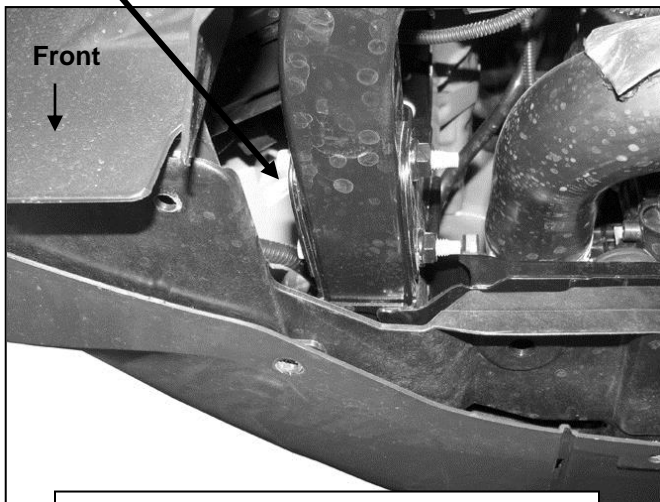

(Fig 2B) Driver side pictured from below

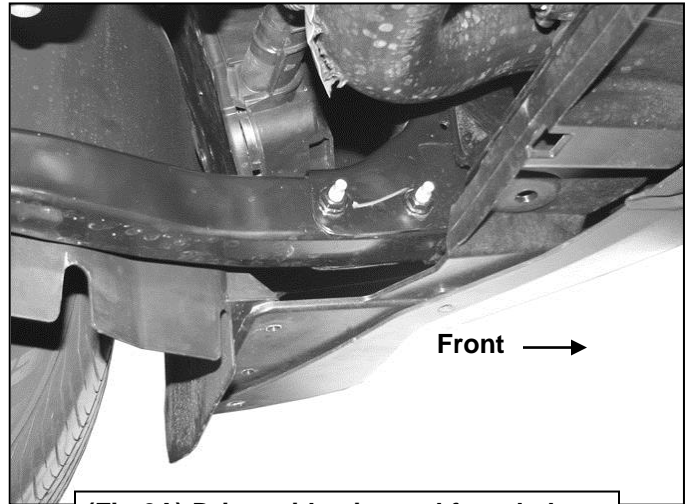

(Fig 2A) Driver side pictured from below

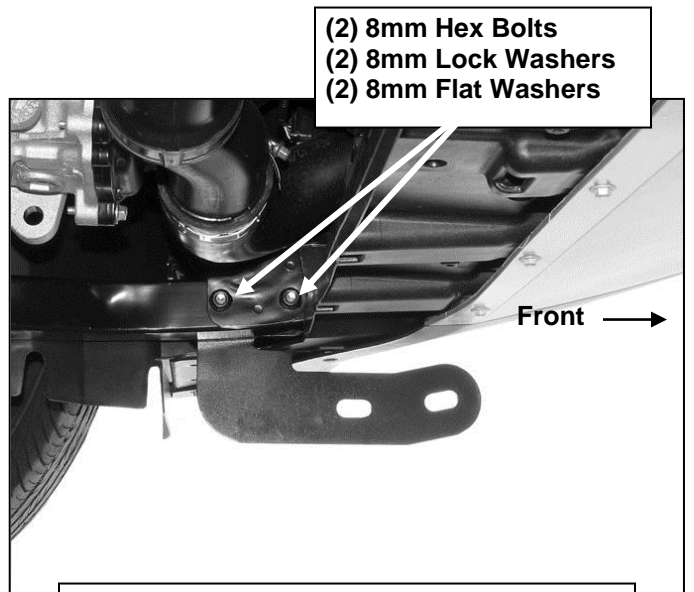

(Fig 3) Driver side Frame Mounting Bracket pictured bolted to outside of subframe

Driver Side Installation Pictured

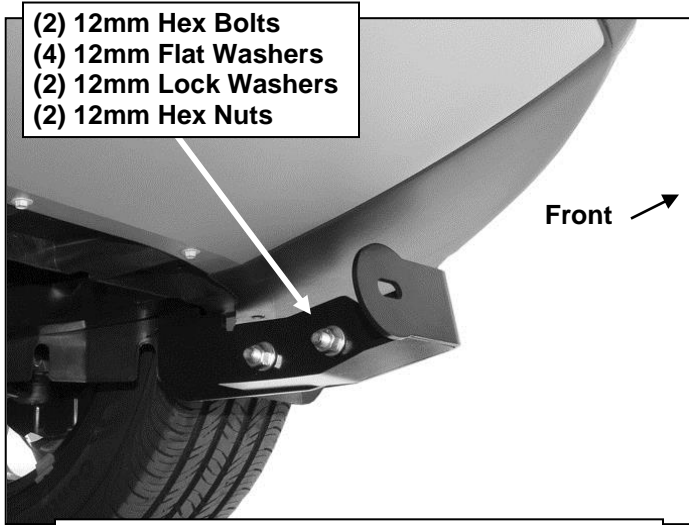

- (2) 12mm Hex Bolts
- (4) 12mm Flat Washers
- (2) 12mm Lock Washers
- (2) 12mm Hex Nuts

Front →

(Fig 4) Driver Side Mounting Bracket Pictured

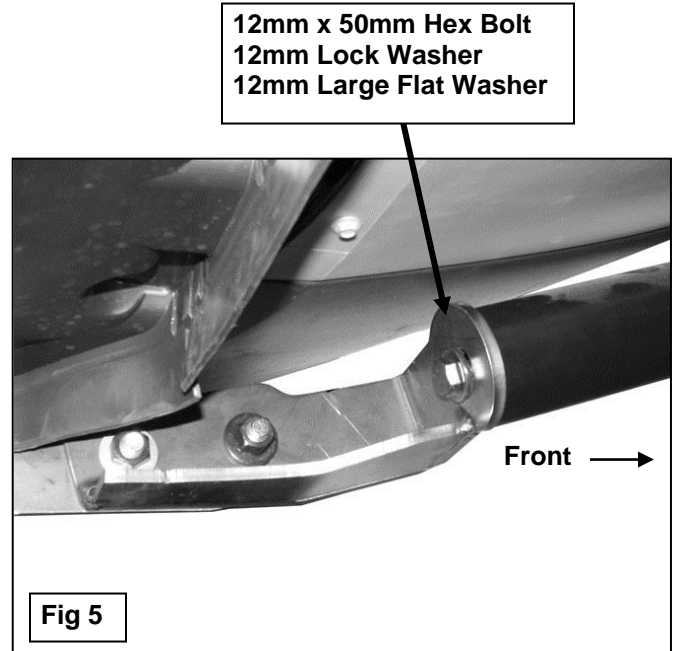

- 12mm x 50mm Hex Bolt
- 12mm Lock Washer
- 12mm Large Flat Washer

Front →

Fig 5

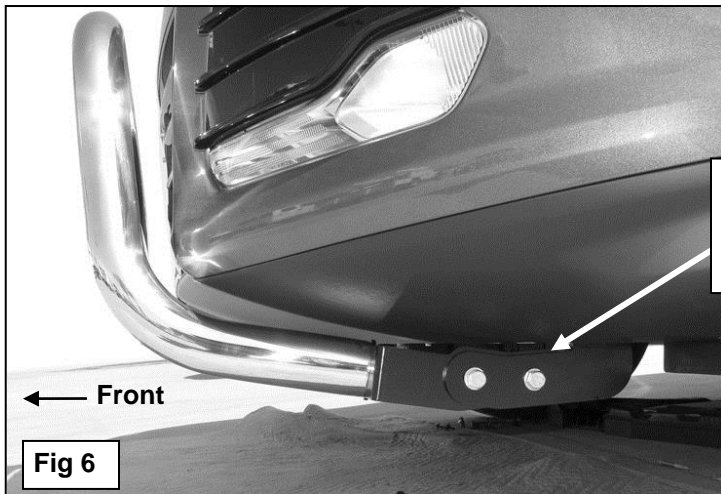

- (2) 12mm Hex Bolts
- (4) 12mm Flat Washers
- (2) 12mm Lock Washers
- (2) 12mm Hex Nuts

← Front

Fig 6



Complete Installation