



AB2223

Endurance Truck Rear Bumper for 19-20 CHEVY SILVERADO 1500
(Excl. vehicles with blind spot monitors)

PARTS LIST:

1	LD2 Rear Bumper	8	12mm x 37mm x 3mm Flat Washers
2	Mesh Plates	4	12mm Lock Washers
4	Sensor Rubber Plugs	4	12mm Hex Nuts
4	Sensor Foam Washers	4	12mm Nylon Lock Nuts
4	Sensor Foam Spacers	6	6-1.0mm x 20mm Button Head Combo Bolts
4	Sensor Retaining Clips	4	6mm Flange Nuts
1	Sensor Cover Kit	8	4-0.75mm x 10mm Button Head Bolts
2	Plastic Plugs for License Plate	1	4mm Allen wrench
4	12-1.75mm x 40mm Hex Bolts	1	2.5mm Allen Wrench
4	12mm Plastic Retainers	10	Nylon Ties

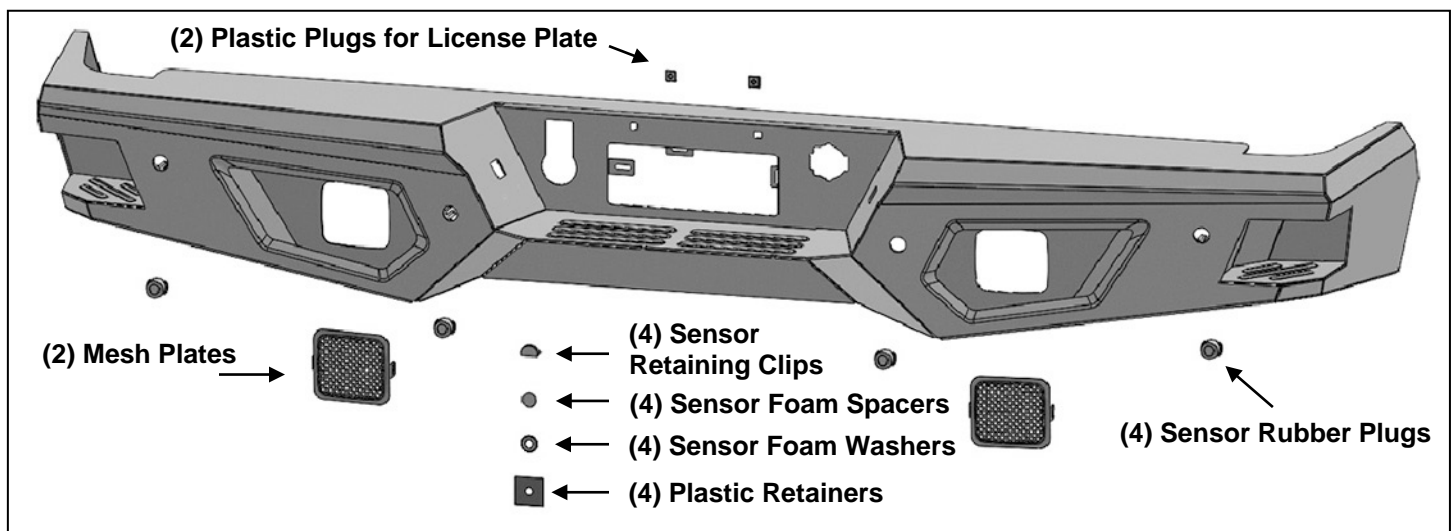

PROCEDURE:

REMOVE CONTENTS FROM BOX. VERIFY ALL PARTS ARE PRESENT. READ INSTRUCTIONS CAREFULLY BEFORE STARTING INSTALLATION. BUMPER IS HEAVY, ASSISTANCE IS HIGHLY RECOMMENDED TO AVOID POSSIBLE INJURY OR DAMAGE TO THE VEHICLE. EXCLUDES MODELS WITH BLIND SPOT MONITORING SYSTEM.

1. Remove the license plate, **(Figure 1)**. Remove the (2) bolts behind the license plate, **(Figure 2)**.
2. Unplug all wiring harnesses leading to the bumper, **(Figure 3)**. Unplug trailer plug, **(Figure 4)**.
3. Place blocks or jack stands under the bumper to support it during mounting bolt removal. Assistance is highly recommended to remove the bumper. Starting on the passenger/right side, remove the factory bolt attaching the outer end of the bumper support to the bottom of the bumper, **(Figure 5)**. Remove the (2) factory flange nuts attaching the bumper to the frame, **(Figure 6)**. Repeat this Step to remove the factory hardware from the driver/left side. With assistance, pull bumper straight out from vehicle.
4. Move the OE rear bumper to stable, flat surface. Disassemble bumper to remove the sensors, if equipped, trailer plug, license lights, remote antenna with Tire Pressure Monitoring System (TPMS) assembly bracket & the spare tire access lock, **(Figure 7)**. Release clips and remove wire harness.
5. Determine if the vehicle is equipped with parking sensors:

Models without bumper sensors:

- a. Select the included (4) Rubber Plugs.



- b. From behind bumper, push plugs into sensor mounting holes, **(Figure 8)**. 4mm Screws have been provided to lock the plugs in the sleeve. Use is optional.

Models with bumper mounted sensors:

- a. Remove the silicone seal from the end of the sensor. Slide the included Foam Washer over front of sensor, **(Figure 9)**.
 - b. Attach (1) Foam Spacer to (1) Retaining Clip.
 - c. Slide the sensor tabs into the sensor sleeve openings on the back of the Rear Bumper. Push and lock the Retaining Clip into the sensor sleeve holes, **(Figure 10)**.
 - d. Repeat the above steps for each rear sensor.
6. Select the driver/left license plate light. Attach the light to the back of the bumper using (1) 6mm Button Head Combo Bolt, **(Figure 11)**. Repeat this Step to install the passenger side factory light.
 7. Select the factory remote antenna with TPMS assembly, **(Figure 12)**. Snap the (3) clips on the bracket into the slots on the back of the bumper mounting tabs, **(Figure 13)**.
 8. Push the provided (2) Plastic Plugs into the square holes in the Bumper to attach the license plate. Snap the trailer plug & spare tire access key into the Rear Bumper, **(Figure 13)**.
 9. Plug the factory wire harness into the sensors, license lights & remote antenna with TPMS assembly.
NOTE: Run the wire harness over the LED light mounting tabs on the back of the Bumper to avoid any interference with the exhaust. If necessary, cut the electrical tape on the wire harness to reach the outer sensors.
10. **If installing LED Lights**, (sold separately).
 - a. Insert light into opening and up to mounting slot, **(Figure 14)**.
 - b. Follow the light manufacturer's instructions to attach (1) light to the mounting tab.
 - c. Repeat the above steps for passenger side light installation.
 - d. Follow light manufacturer's instructions to properly wire the light.
 11. **If installing Mesh Plates instead of LED Lights:**
 - a. Select (1) Mesh Plate. Attach the Mesh Plate to the back of the Bumper using (2) 6mm Button Head Combo Bolts and (2) 6mm Flange Nuts, **(Figure 14)**.
 12. Remove the (2) bumper support brackets from the outside of the frame, **(Figure 15)**.
 13. Determine the model of the vehicle.
1500 models:

Select (2) 12mm x 40mm Hex Bolts and (2) 12mm Flat Washers. Insert the Hex Bolts with Washers through the **OUTER SLOTS** in the back of the passenger/right bumper mounting bracket, **(Figure 16)**. Thread (2) Plastic Retainers onto the Hex Bolts. **NOTE:** The Plastic Retainers are used to hold the Hex Bolts in place during Bumper installation. Repeat this Step to install (2) 12mm Hex Bolts and (2) 12mm Flat Washers on the driver/left side of the Bumper.

25-3500 models:

Repeat the previous Step to insert (2) 12mm x 40mm Hex Bolts and (2) 12mm Flat Washers into the **INNER SLOTS** on the back of the passenger/right bumper mounting bracket, **(Figure 17)**. Thread (2) Plastic Retainers onto the Hex Bolts. Repeat this Step to install (2) 12mm Hex Bolts and (2) 12mm Flat Washers on the driver/left side of the Bumper.
 14. Temporarily support the weight of the Bumper. **WARNING:** To avoid possible injury or damage to the vehicle, do not proceed until the Bumper is fully and safely supported. With assistance, position the Bumper Assembly up to the frame.
 15. Attach the Bumper to the frame with (4) 12mm Flat Washers and (4) 12mm Nylon Lock Nuts, **(Figure 18)**. Do not fully tighten hardware at this time.
 16. Level and adjust the position of the bumper. Slowly open tailgate and check for clearance. Adjust as necessary and fully tighten all hardware.
 17. Reuse factory hardware to attach the license plate.
 18. Plug the bumper wire harness & trailer plug into the vehicle harness.
 19. Use the included Wire Ties to secure the wiring harness to the bumper and frame as necessary.
 20. Do periodic inspections to the installation to make sure that all hardware is secure and tight.



To protect your investment, Do not use any type of polish or wax that may contain abrasives that could damage the finish. Mild soap may be used to clean the Bumper assembly.

Passenger/right side installation pictured

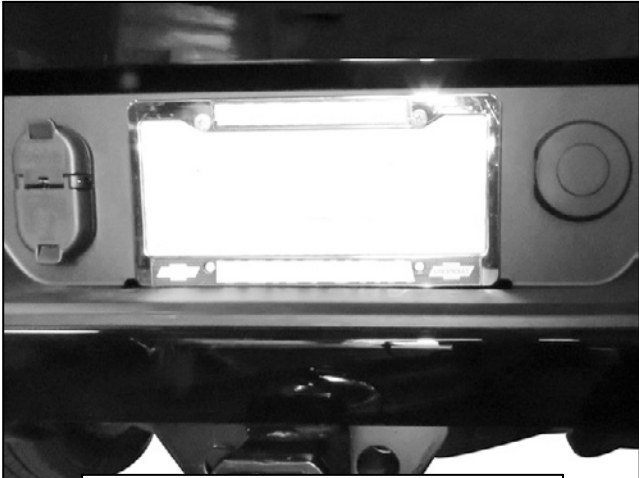

(Fig 1) Remove the license plate

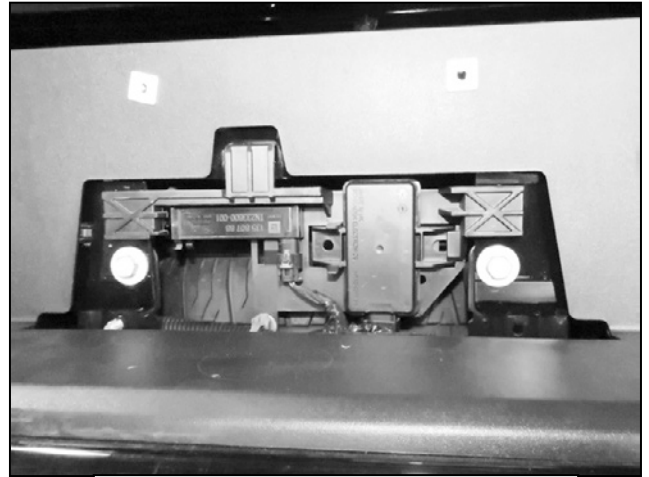

(Fig 2) Remove the (2) factory bolts from behind the license plate

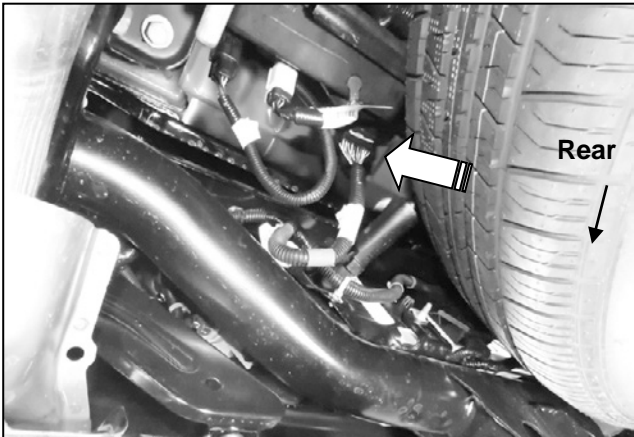

(Fig 3) Unplug wire harness leading to Bumper

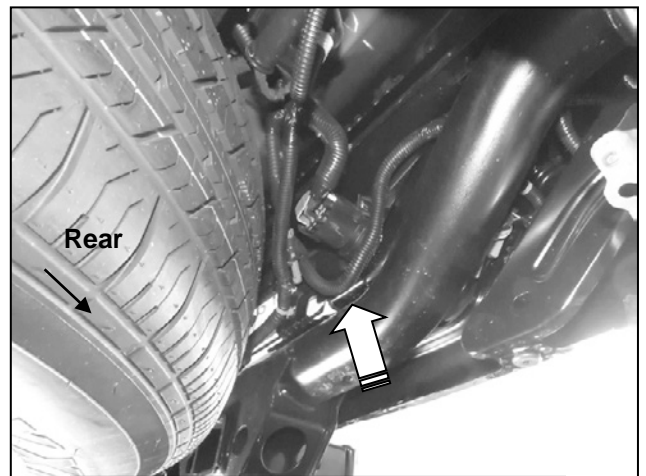

(Fig 4) Unplug the trailer towing plug

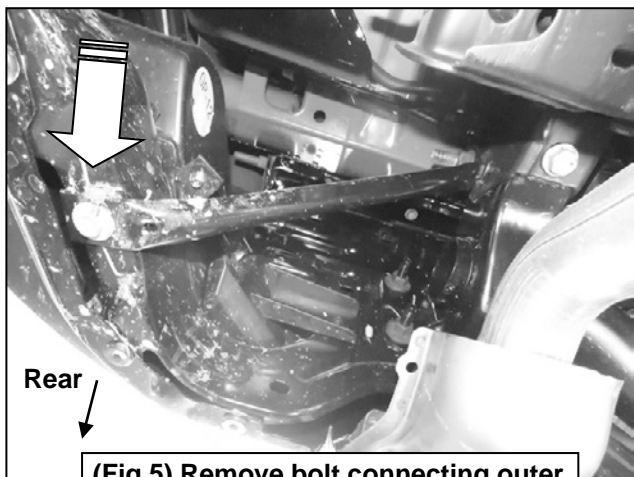

(Fig 5) Remove bolt connecting outer support bracket to bumper



Passenger/right side installation pictured

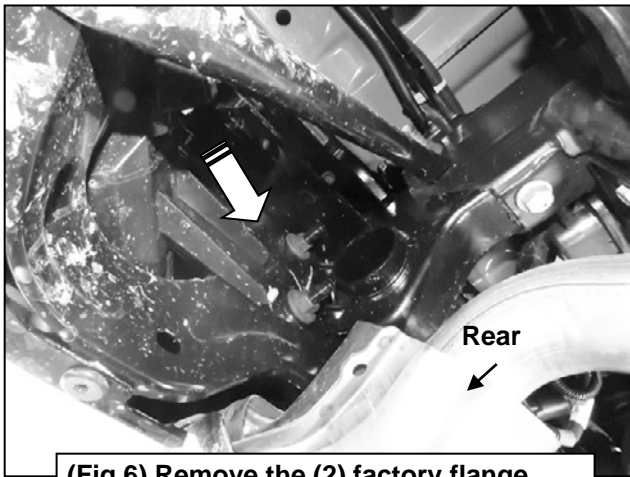

(Fig 6) Remove the (2) factory flange nuts attaching the bumper to the frame

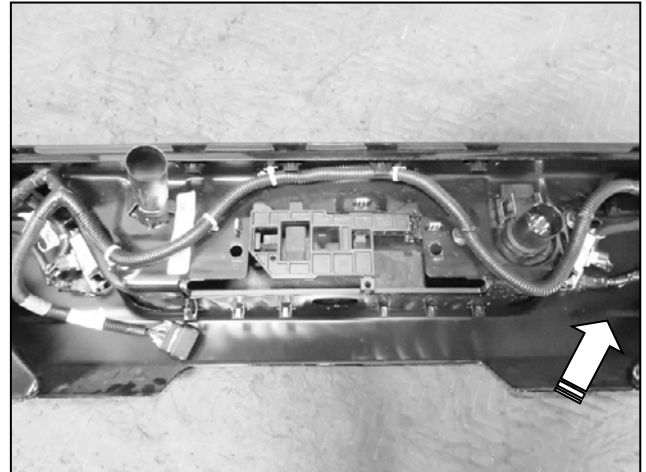

(Fig 7) Unplug and remove the sensors, license lights, trailer plug, remote antenna with TPMS assembly, & spare tire access key from the back of the bumper. Release and remove wire harness.

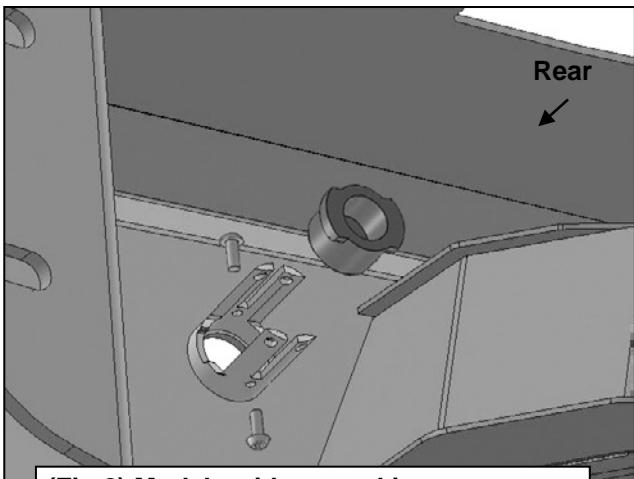

(Fig 8) Models without parking sensors, insert Rubber Plugs into sensor mounts

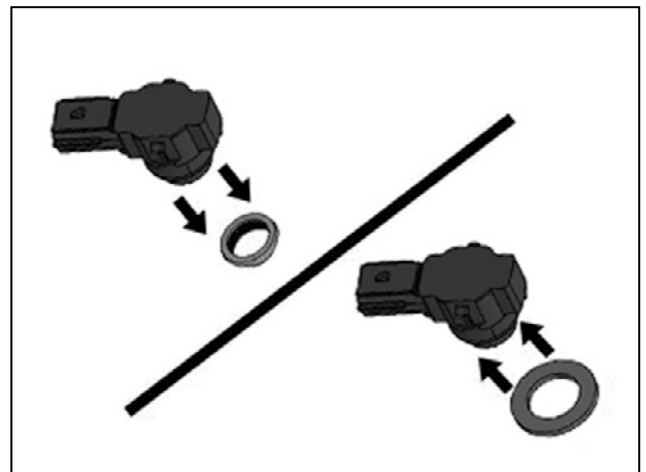

(Fig 9) Remove silicone seal from sensor. Slide Foam Washer over end of sensor (arrow)

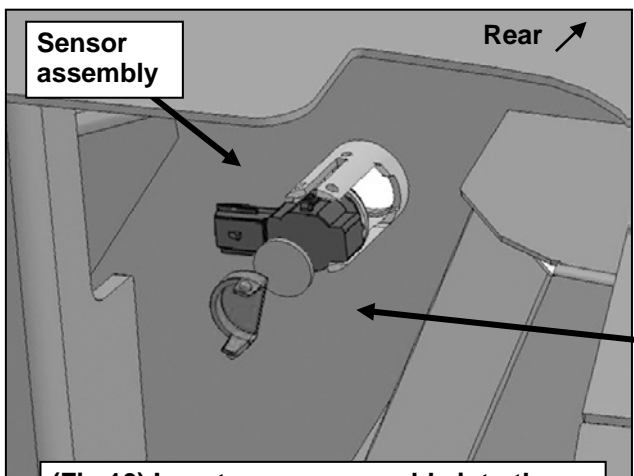

(Fig 10) Insert sensor assembly into the sensor sleeve. Secure with Retaining Clip.



Passenger/right side installation pictured

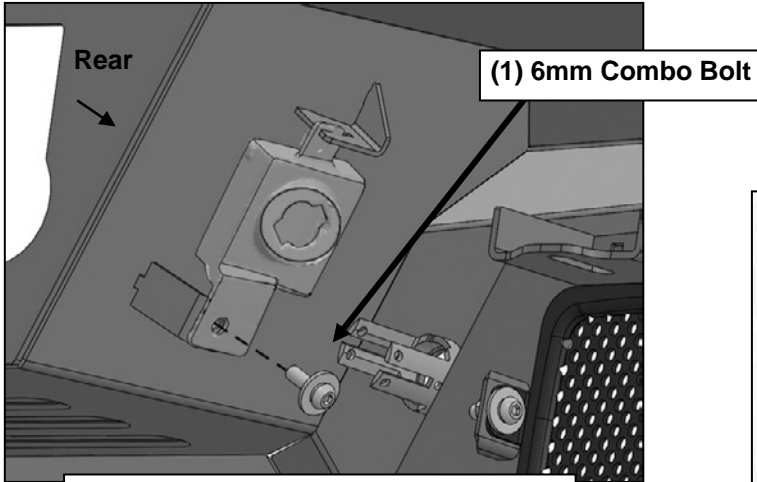

(Fig 11) Attach driver/left side factory license plate light to the Bumper

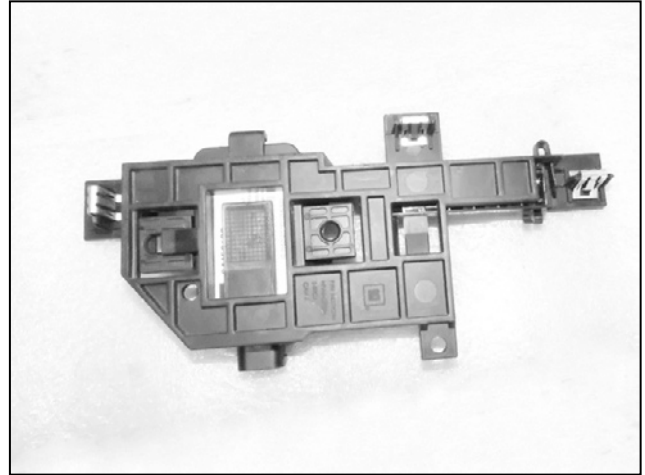

(Fig 12) Remote antenna with TPMS assembly

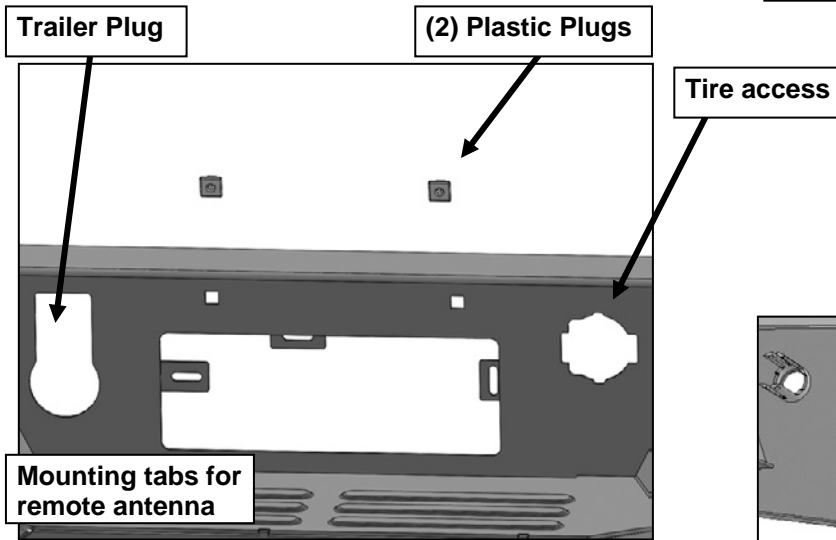

(Fig 13) Attach trailer plug, spare tire access key and remote antenna assembly. Push Plastic Plugs into square holes for license plate

(2) 6mm Combo Bolts
(2) 6mm Flange Nuts

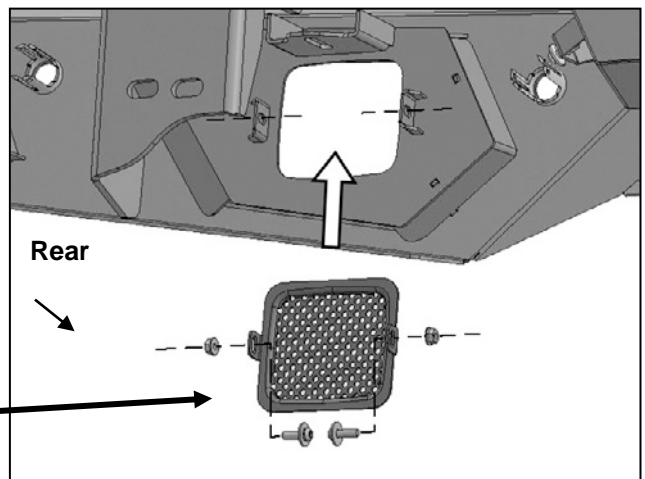

(Fig 14) Attach Mesh Fill Panel to tabs on back of Bumper



Passenger/right side installation pictured

WARNING! Fully support the weight of the bumper with blocks or stands to prevent injury or damage to the vehicle.

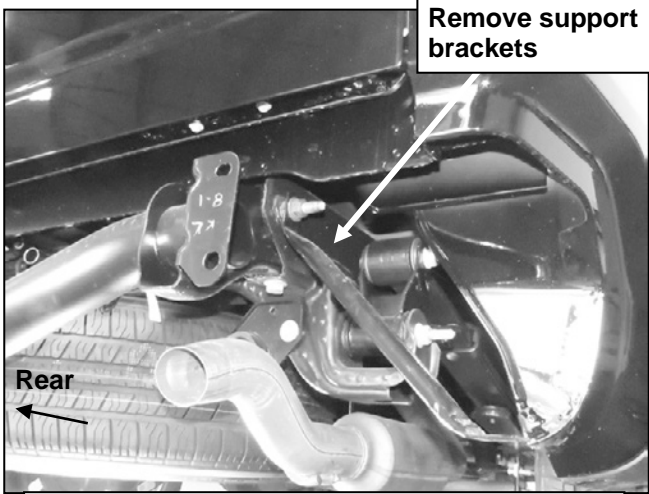

(Fig 15) Remove the bumper support brackets attached to the outside of the frame

(2) 12mm Plastic Retainers

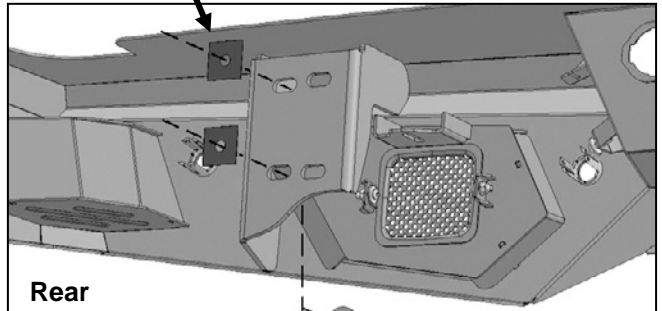

(Fig 16) On 1500 models, insert hardware into OUTER mounting slots. Thread Plastic Retainers onto Hex Bolts to hold Bolts in place

(2) 12mm Plastic Retainers
 (2) 12mm Flat Washers
 (2) 12mm x 40mm Hex Bolts

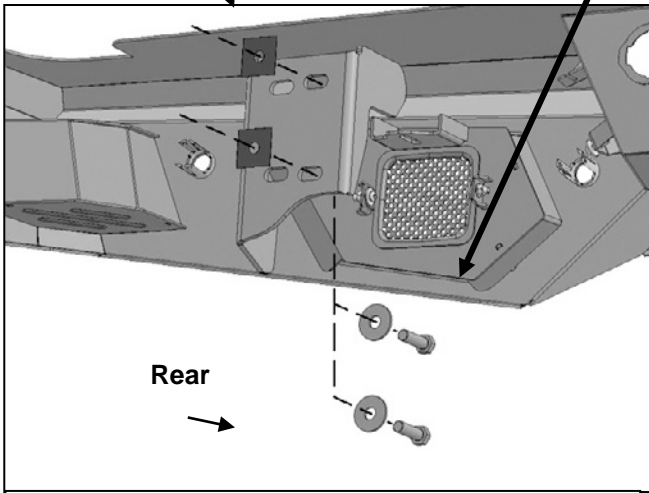

(Fig 17) On 25-3500 models, insert hardware into INNER mounting slots. Thread Plastic Retainers onto Hex Bolts to hold Bolts in place

(2) 12mm Flat Washers
 (2) 12mm Nylon Lock Nuts

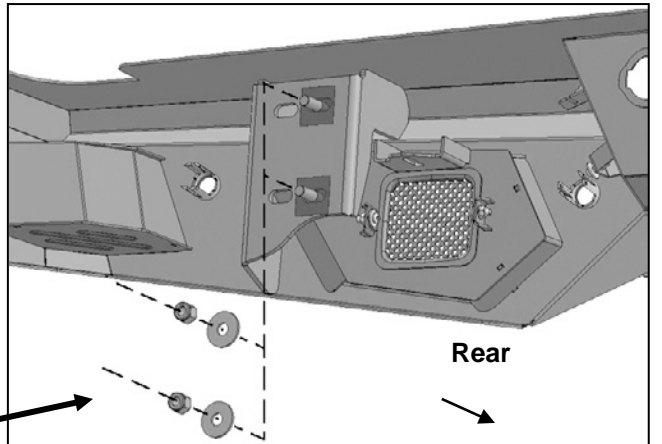

(Fig 18) Attach Bumper to end of frame (passenger/right side of 1500 model illustrated)