

INSTALLATION INSTRUCTIONS

APPLICATION:

2014–2018 Chevrolet Silverado 1500

ITEM	QUANTITY	DESCRIPTION	TOOLS NEEDED
1	1	GRILLE GUARD ASSEMBLY	15MM SOCKET
2	2	LOWER SUPPORT BRACKET	18MM SOCKET
3, 4	2	LOWER MOUNTING BRACKET, DRIVER (5) AND PASSENGER (6)	15MM WRENCH
5, 6	2	TOP SUPPORT STRAP, DRIVER (5) AND PASSENGER (6)	18MM WRENCH
7	4	SHORT M12-35 HEX HEAD CAP SCREW (YELLOW ZINC)	SCREW DRIVER
8	2	LONG M12-130 (teeth 55mm) HEX HEAD CAP SCREW (YELLOW ZINC)	UTILITY KNIFE
9	6	M12 SPLIT LOCK WASHER (YELLOW ZINC)	RATCHET
10	12	M12 FLAT WASHER (YELLOW ZINC)	TORQUE WRENCH
11	6	M12 HEX NUT (YELLOW ZINC)	
12	10	M10-30 SOCKET BUTTON HEAD BOLT (RAW OR BLACK ZINC)	
13	10	M10 BELLEVILLE WASHER (RAW OR BLACK ZINC)	
14	10	M10 SERRATED FLANGE NUT (RAW OR BLACK ZINC)	ITEMS 12-17 ARE STAINLESS STEEL
15	4	M12-35 HEX SOCKET BUTTON HEAD BOLT (RAW OR BLACK ZINC)	
16	4	M12 SERRATED FLANGE NUT (RAW OR BLACK ZINC)	
17	4	M12 BELLEVILLE WASHER (RAW OR BLACK ZINC)	
	1	6mm wrench	
	1	8mm wrench	

ANTI-SEIZE LUBRICANT MUST BE USED ON ALL STAINLESS STEEL FASTENERS TO PREVENT THREAD DAMAGE AND GALLING

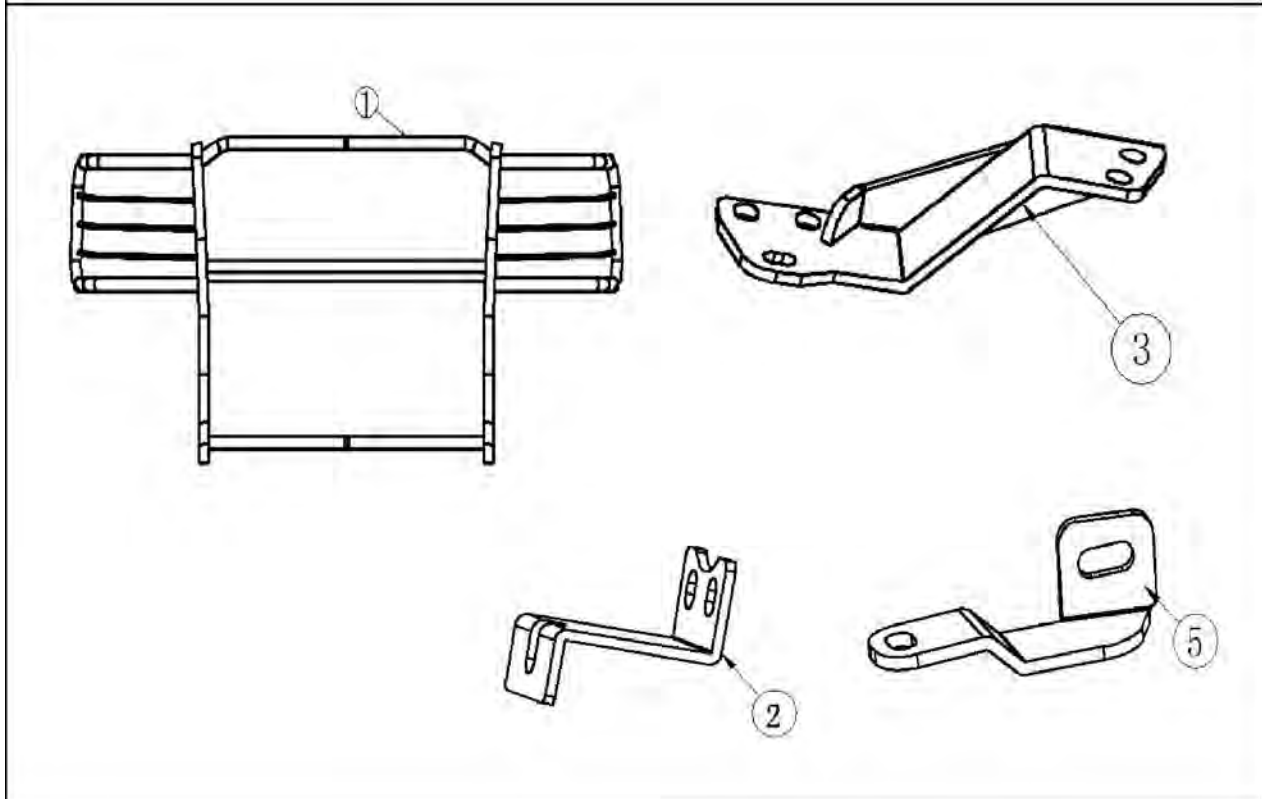

PROCEDURE

1. Remove contents from box, verify if all parts listed are present and free from damage.
Carefully read and understand all instructions before attempting installation.
Failure to identify damage before installation could lead to a rejection of any claim.
2. Remove the radiator cover to reveal screws that attach the grille to the front of vehicle. See Figure 1.
3. Remove the screws that attach the grille to the front of vehicle. Carefully pull the grille off the vehicle. See Figure 2.

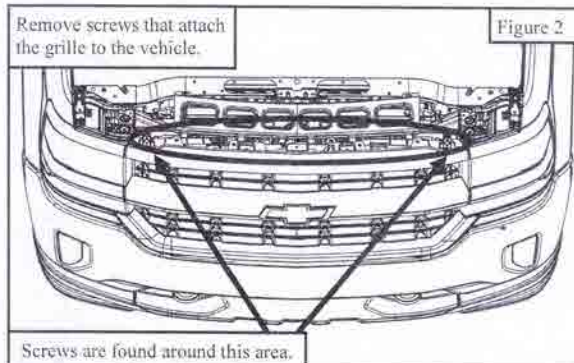

4. Remove the front bumper assembly. (This is only necessary for vehicles with factory tow hooks.) See Figures 3 and 4.

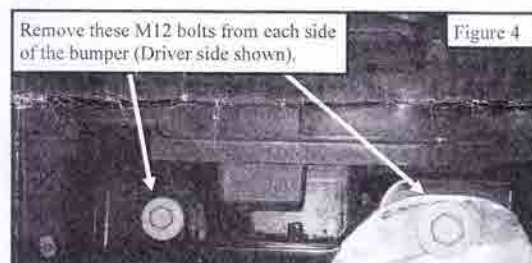
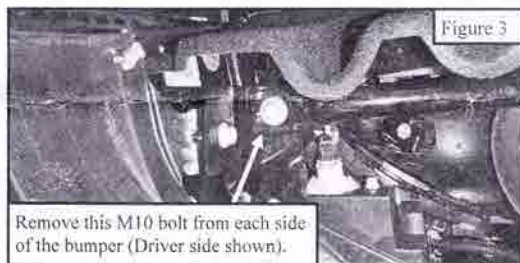

5. *For models with factory tow hooks:* Remove the tow hook bolts and the foam tow hook covers. Tow hooks can be reinstalled with application. See Figures 5 and 6.
6. *For models without factory tow hooks:* Trim the tow hook pockets in the front valance.

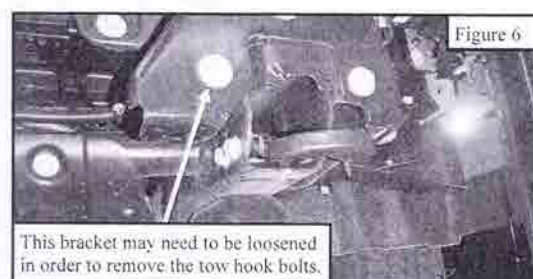
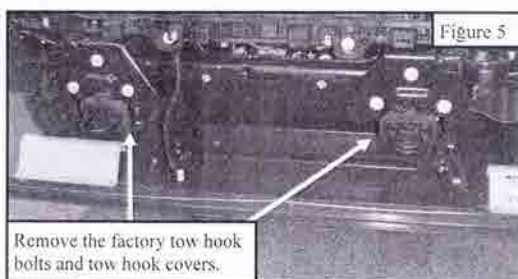

7. Locate (1) Lower Mounting Bracket (Item 3/4) and (1) Lower Support Bracket (Item 2). Loosely attach the Lower Mounting Bracket, Lower Support Bracket, and factory tow hooks to frame rail using the provided hardware: (1) long M12 hex head cap screw, (2) short M12 hex head cap screw (6) M12 flat washers, (3) M12 split lock washers, and (3) M12 hex nuts. See Figures 7 and 8. Note: Factory hardware may be re-used on vehicles with factory tow hooks.

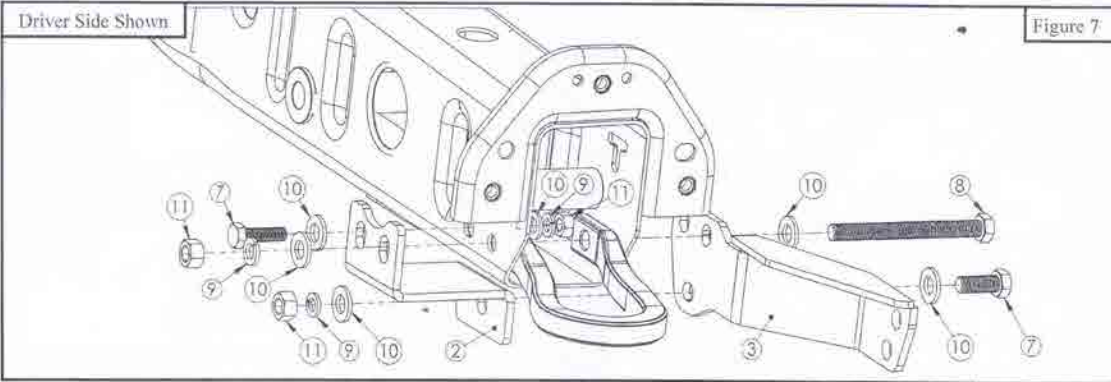

8. Reinstall bumper (if removed). Trim tow hook pockets as necessary.
 9. Locate (1) Top Support Strap (Item 5/6). Remove factory hardware at mounting location. Loosely install Top Support Strap with the factory hardware located at the mounting location. Adjust them so that they are approximately 20-5/8" from the center of the bumper then torque the factory hardware to 50-55 ft-lb. See Figures 9, 10 and 11.
 10. Repeat steps 7 and 9 for the other side (passenger or driver).

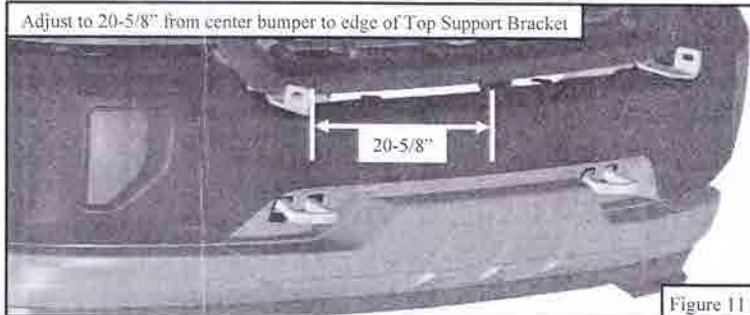
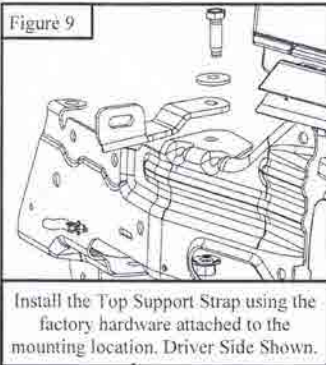
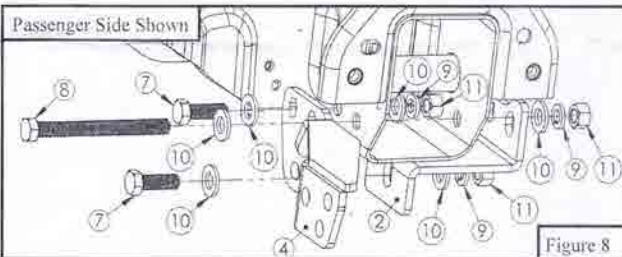

10. Re-install grille and radiator cover in the reverse order that they were removed.
11. The Grille Guard is assembled using the supplied M8 hardware (Items 18-20). See **Figure 11-1**.
12. With assistance loosely install the Grille Guard Assembly (Item 1) onto the previously installed brackets. Loosely bolt the Top Support Straps (Items 5 & 6) onto the Grille Guard using the supplied M10 hardware (Items 12-14). Loosely bolt the Lower Mounting Brackets (Items 3 & 4) using the supplied M12 hardware (Items 15-17). See **Figure 12**.
13. Align and adjust the Grille Guard as necessary. Tighten all remaining hardware: M10 to 30-35 ft-lbs and M12 to 50-55 ft-lbs.

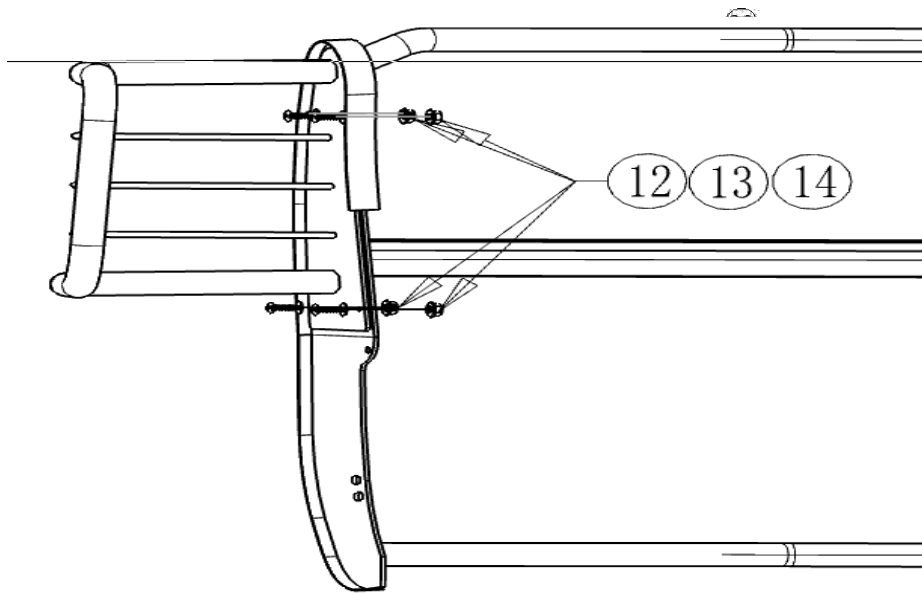

Figure 11-1

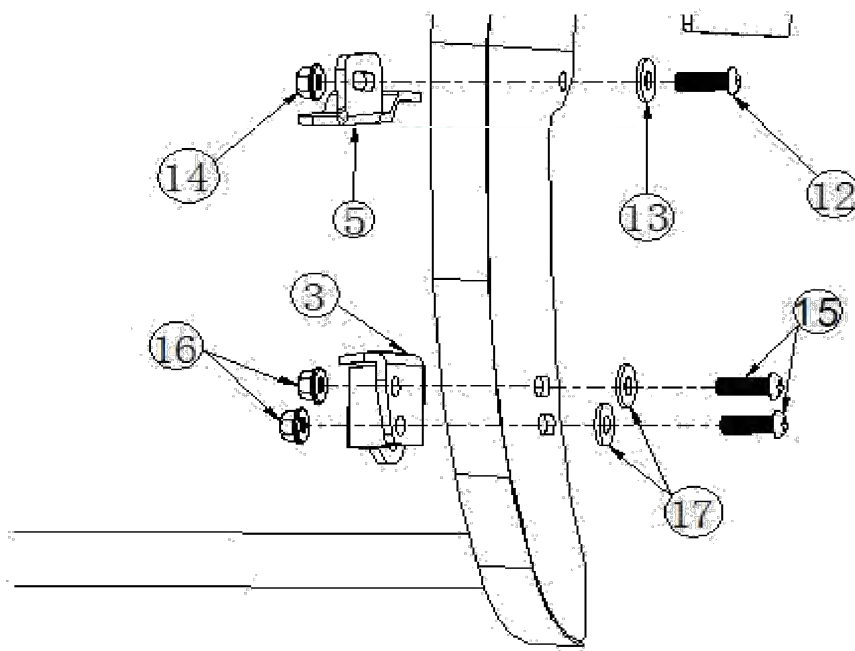

Figure 12



WARNING



Failure to follow these instructions could lead to death, personal injury, and / or property damage.

FASTENERS:

All Westin supplied fasteners must be utilized and installed in accordance with the installation instructions and apply torque to the specifications as defined. **DOUBLE CHECK ALL FASTENERS BEFORE INITIAL USE, AND PERIODICALLY IN THE FUTURE TO ENSURE PROPER FUNCTION AND SAFETY.**

DRILLING:

Most Westin products do not require drilling for installation. If drilling is defined as required, use caution when drilling a vehicle. **FAILURE TO REVIEW AN AREA TO BE DRILLED MAY RESULT IN PERSONAL INJURY AND/OR INJURY TO OTHERS AS WELL AS VEHICLE DAMAGE.**

EYE PROTECTION:

ALWAYS WEAR SAFETY GLASSES OR GOGGLES DURING THE INSTALLATION PROCESS TO AVOID PERSONAL INJURY.

MAXIMUM TOWING/CARRYING CAPACITY:

The Westin Receiver Hitches will have a visible tow rating label affixed directly on the product. User should never exceed the vehicle manufacturers maximum tow and weight rating regardless of the capacity of the hitch. **FAILURE TO FOLLOW THESE GUIDELINES WILL VOID THE WESTIN WARRANTY AND MAY RESULT IN PERSONAL INJURY AND/OR INJURY TO OTHERS AS WELL AS VEHICLE DAMAGE.**