

INSTALLATION INSTRUCTIONS

GRILLE GUARD

07-14 TOYOTA FJ CRUISER

PART # VGBGG-0578BK



PARTS LIST:

1	Grill Guard	4	10-1.5mm x 120mm x 30mm Hex Bolts
1	Driver/Left Lower Frame Bracket	8	10mm x 30mm OD x 2.5mm Flat Washers
1	Passenger/Right Lower Frame Bracket	4	10mm x 20mm x 2mm Flat Washers
1	Driver/Left Top Support Bracket	6	10mm Nylon Lock Nuts
1	Passenger/Right Top Support Bracket	4	8-1.25mm x 25mm Hex Bolts
1	Driver/Left Top Mounting Bracket	4	8mm ID x 16mm OD x 1.6mm Flat Washers
1	Passenger/Right Top Mounting Bracket	4	8mm Lock Washers
4	12-1.75mm x 30mm Hex Bolts	4	6-1.0mm x 25mm Hex Bolts
8	12mm x 37mm OD x 3mm Flat Washers	4	6mm x 12mm OD x 1.6mm Flat Washers
4	12mm Nylon Lock Nuts	4	6mm Lock Washers
2	10-1.5mm x 30mm Button Head Allen Bolts	1	6mm Allen Wrench

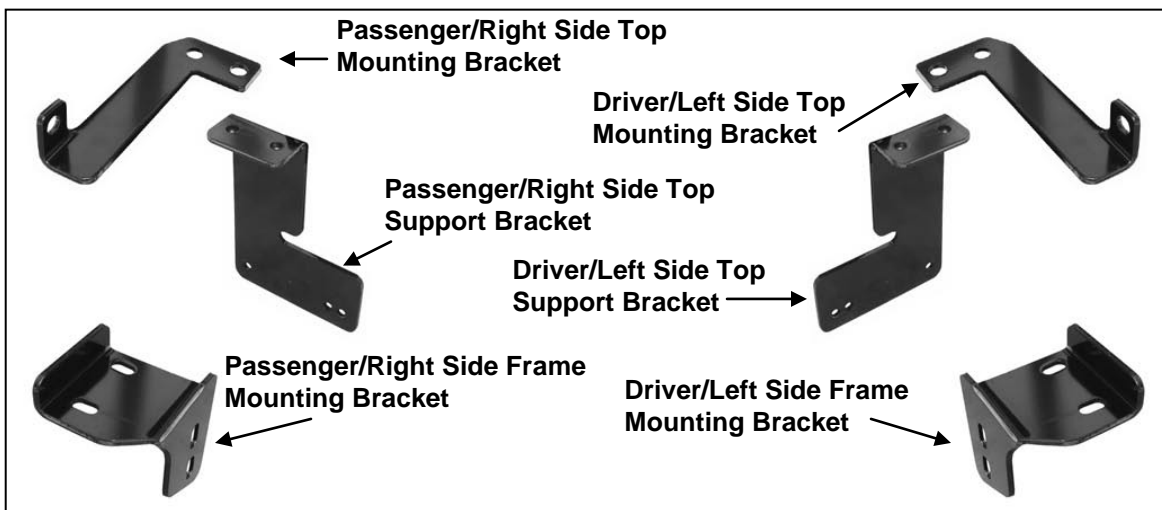

PROCEDURE:

- 1. REMOVE CONTENTS FROM BOX. VERIFY ALL PARTS ARE PRESENT. READ INSTRUCTIONS CAREFULLY BEFORE STARTING INSTALLATION. DO NOT ATTEMPT INSTALLATION ALONE; PERSONAL INJURY OR DAMAGE TO THE VEHICLE MAY RESULT.**
- Remove the factory skip plate if equipped. Starting behind the front bumper on the driver side, locate the section of rectangular frame channel attached to the back of the bumper, (**Figure 1**). Insert (2) 10mm x 120mm Hex Bolts with (2) 10mm x 30mm Large Flat Washers into and down through the (2) vertical holes in the top of the bumper bracket, (**Figures 2 & 3**). Select the driver side Frame Mounting Bracket. Line up the (2) slots in the Bracket with the (2) 10mm Hex Bolts. Secure the Bracket to the bottom of the bumper bracket with (2) 10mm x 30mm Large Flat Washers and (2) 10mm Nylon Lock Nuts, (**Figures 4A & 4B**). Do not tighten hardware.
- Repeat **Step 2** for passenger side Frame Bracket installation.
- Next, remove the plastic grille and place it on a clean, stable work surface.
- Select the driver side Top Support Bracket, (**Figure 5B**). Line up the holes in the bottom of the Support Bracket with the threaded holes in the crossmember. Bolt the Support Bracket to the crossmember with (2) 6mm x 25mm Hex Bolts, (2) 6mm Lock Washers and (2) 6mm Flat Washers, (**Figures 5A – 5C**). **NOTE:** Replace factory 6mm screws, (if equipped), from crossmember with 6mm hardware. Fully tighten the 6mm hardware only at this time.

6. Repeat **Step 5** to install the passenger side Top Support Bracket.
7. Reinstall the grille using the factory hardware.
8. Select the driver side Top Bracket, (**Figure 6B**). Insert the Bracket through the gap between the bottom of the grille and the top of the bumper, (**Figure 6A**). Line up the (2) holes in the Top Bracket with the (2) threaded holes in the Support Bracket, (**Figure 7**). Bolt the Top Bracket to the Support Bracket with the included (2) 8mm x 25mm Hex Bolts, (2) 8mm Lock Washers and (2) 8mm Flat Washers, (**Figure 8**). Snug but do not fully tighten hardware.
9. Repeat **Step 8** for passenger side Top Bracket installation.
10. With assistance, position the Grille Guard onto the outside of the Frame Mounting Brackets. Use the included (4) 12mm x 30mm Hex Bolts, (8) 12mm Flat Washers and (4) 12mm Nylon Lock Nuts to attach the Grille Guard to the Frame Brackets, (**Figure 9**).
11. Line up the mounting hole in the driver side Top Bracket with the corresponding hole in the upright on the Grille Guard. Bolt the Top Bracket to the Grille Guard with the included (1) 10mm x 30mm Button Head Bolt, (2) 10mm x 20mm Small Flat Washers and 10mm Nylon Lock Nut. Do not tighten hardware at this time. Repeat this Step to bolt the passenger side Top Bracket to the Grille Guard.
12. Align the Grille Guard properly and tighten all Bracket mounting hardware including the Top Bracket to Support Bracket hardware.
13. Temporarily remove the Grill Guard. Reinstall the factory skid plate. Reinstall the Grille Guard and tighten all hardware, (**Figure 9**).
14. Do periodic inspections to the installation to make sure that all hardware is secure and tight.

To protect your investment, wax this product after installing. Regular waxing is recommended to add a protective layer over the finish. Do not use any type of polish or wax that may contain abrasives that could damage the finish.

For stainless steel: Aluminum polish may be used to polish small scratches and scuffs on the finish. Mild soap may be used also to clean the Grille Guard.

For gloss black finishes: Mild soap may be used to clean the Grille Guard.

Driver Side Installation Pictured

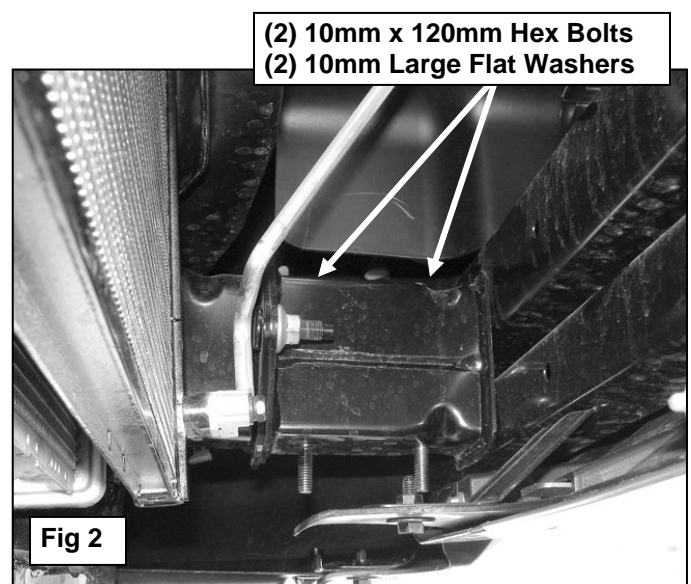
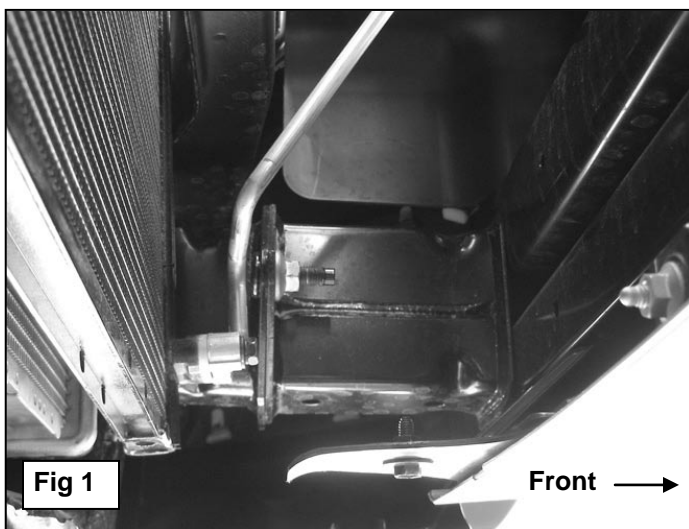

Driver Side Installation Pictured

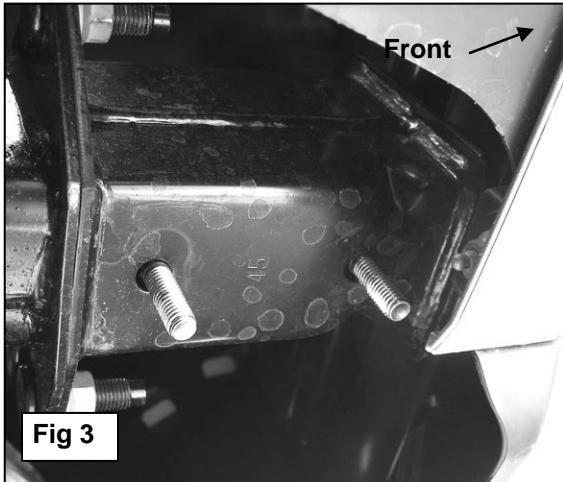

Fig 3

- (2) 10mm x 120mm Hex Bolts
- (2) 10mm Large Flat Washers

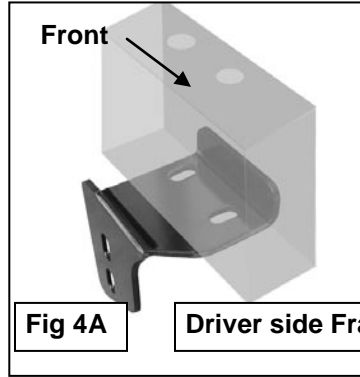

Fig 4A

Driver side Frame Bracket

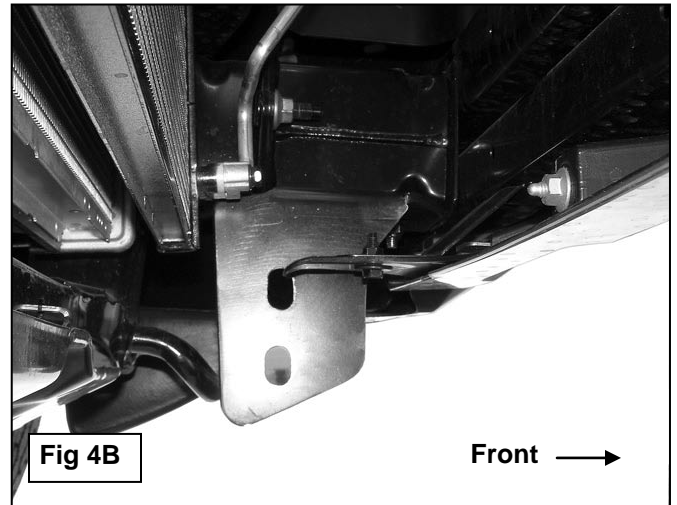

Fig 4B

Front

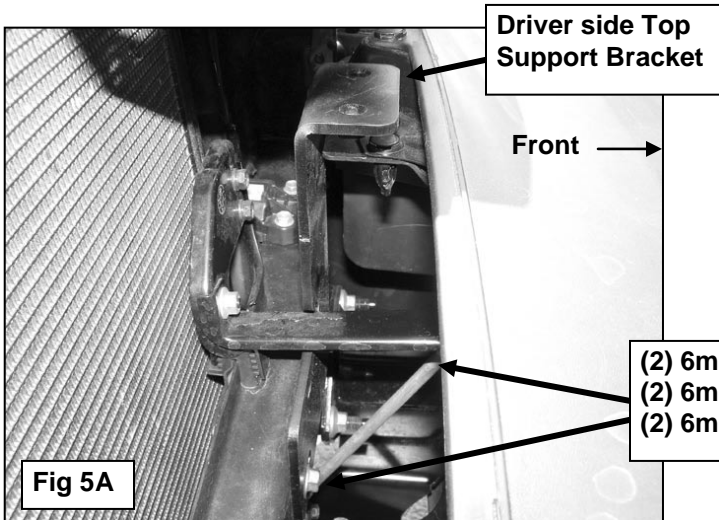

Fig 5A

Driver side Top Support Bracket

- (2) 6mm x 25mm Hex Bolts
- (2) 6mm Flat Washers
- (2) 6mm Lock Washers

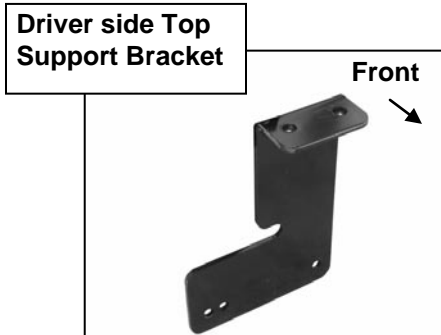
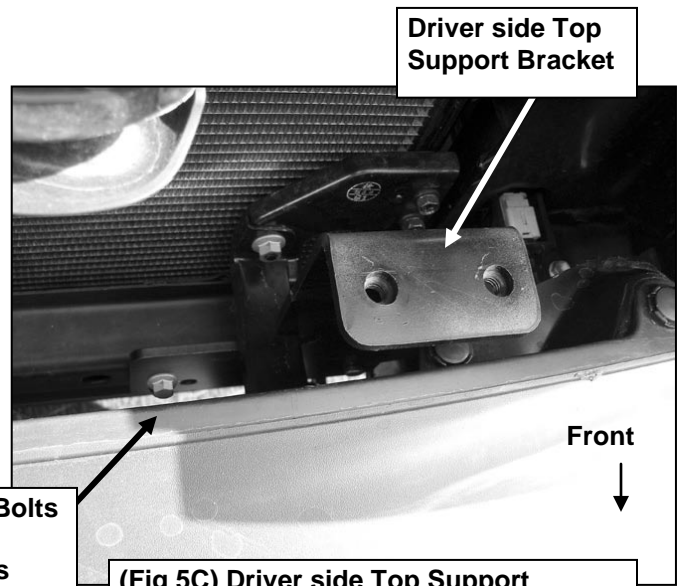

Fig 5B

- (2) 6mm x 25mm Hex Bolts
- (2) 6mm Flat Washers
- (2) 6mm Lock Washers



Driver side Top Support Bracket

(Fig 5C) Driver side Top Support Bracket installation pictured without

Driver Side Installation Pictured



(Fig 6A) Insert Driver side Top Bracket through gap above bumper

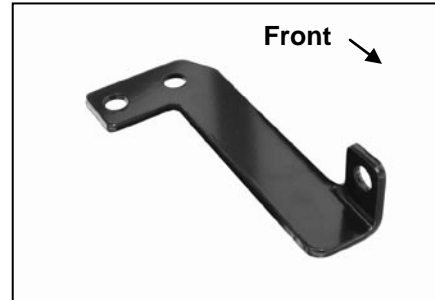

(Fig 6B) Driver side Top Bracket

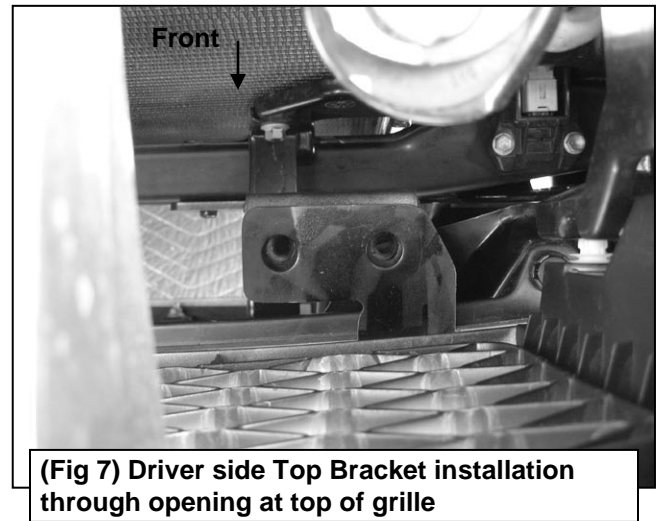

(Fig 7) Driver side Top Bracket installation through opening at top of grille

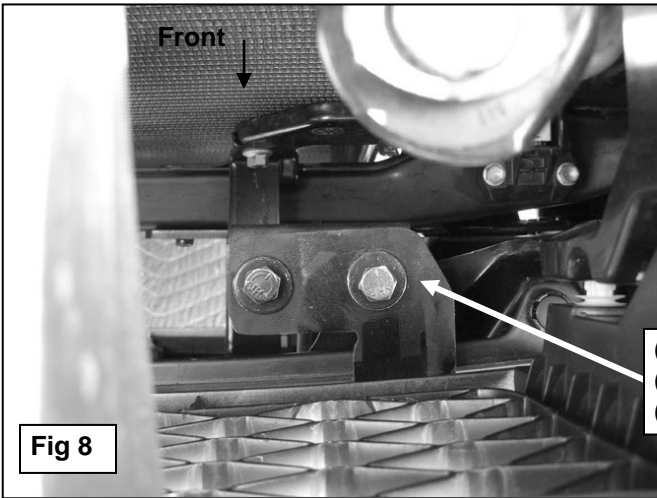

Fig 8

- (2) 8mm x 25mm Hex Bolts
- (2) 8mm Flat Washers
- (2) 8mm Lock Washers

- (2) 12mm x 30mm Hex Bolts
- (4) 12mm Flat Washers
- (2) 12mm Nylon Lock Nuts

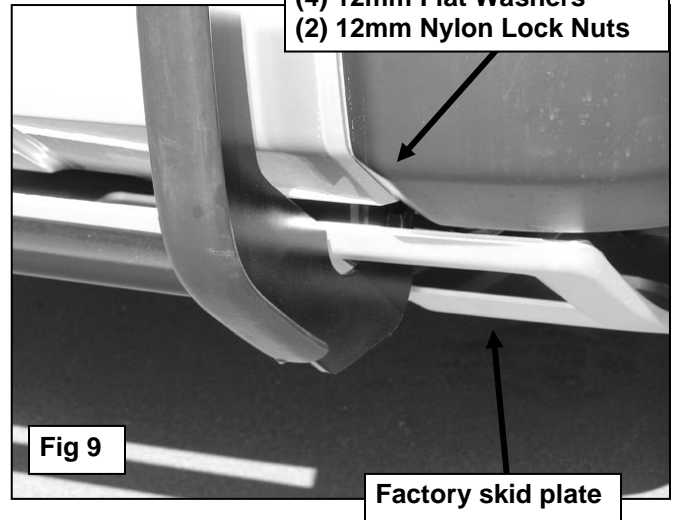

Fig 9

Factory skid plate

